

5044-32T

Fine Material Washer

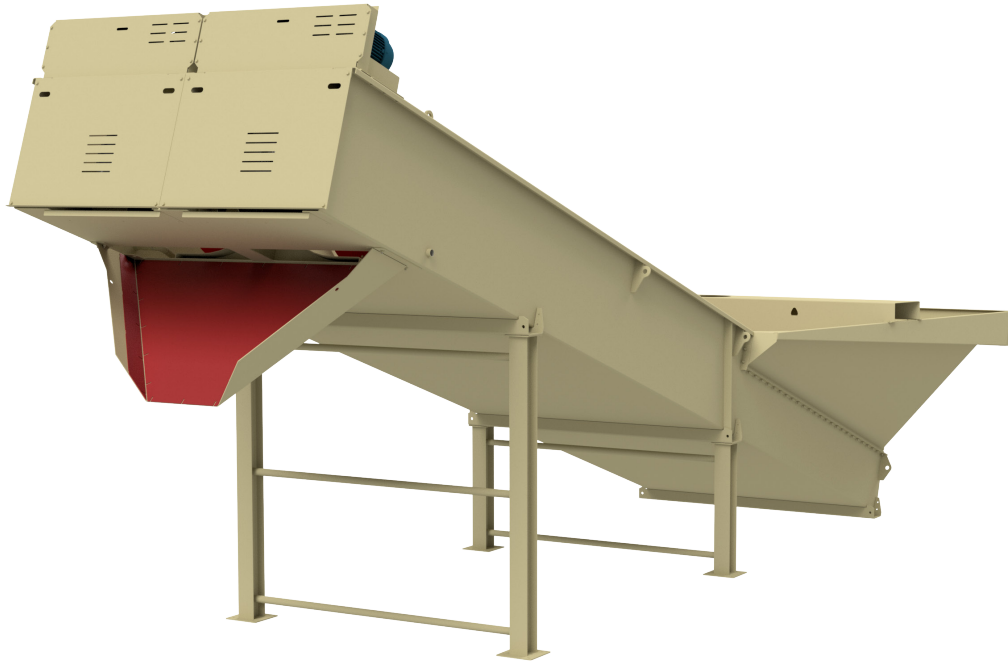

Main Tank

- 1/4" (sides & bottom) and 3/8" (rear end plate) welded plate steel construction
- Curved bottom with integral rising current manifold (4" dia. inlet)
- Large undisturbed pool area
- 26' of adjustable weir boards
- 1-1/2" chase water line connection
- Overflow flume with dual 12" dia. outlets
- 4" dia. tank drain

Spiral Assembly

- Spiral pipe - heavy wall 14" dia.
- Double pitch, solid flight spiral (one right hand, one left hand)
- Standard AR steel inner wear shoes
- Standard urethane outer wear shoes (cast Ni-Hard outer wear shoes are optional)
- Greaseable, externally mounted Dodge Imperial E tail end flange bearing
- Greaseable Dodge Type E pillow block head end bearing
- Lower end seal - chrome plated stainless steel wear sleeve, water tight bellows type rubber seal and secondary grease seal

Drive Assembly (One Drive Assembly Per Spiral)

- High efficiency v-belt drive assembly
- TEFC motor, HP dependent upon spiral speed - see "Raking & Overflow Capacity Table"
- Dodge TA-II double reduction shaft mount reducer

Center Feed Box

- 14-1/2" dia feed inlet
- Internally and externally baffled

Discharge Chute (Optional)

- Tapered discharge chute set at 45o angle to grade

Support Assembly (Optional)

- Independent mid and head end support weldments with 6" wide flange columns

Rising Current Accessories (Optional)

- Externally mounted manifold with 4" butterfly flow control valve, 4" swing check valve, 0-100 psi pressure gauge and 1-1/2" gate valve and plumbing to the chase water connection

Physical and Operating Characteristics

Dimension	Standard	Metric
Feed Material Size	-3/8"	-9.53mm
Angle of Operation	18.5°	18.5°
Capacity Up To	350 TPH	318 MTPH
Shaft Speed Up To	17 RPM	0.28 Hz
Water Requirements Up To	2,700 GPM	613 m ³ /h
Operational Length	35' 7"	10.85m
Operational Width	16' 4"	4.98m
Operational Height	15' 3"	4.65m
Approximate Dead Load	26,900lb	119.66 kN
Approximate Live Load	75,100lb	334.06 kN
Approximate Total Load	102,000lb	453.72 kN

Overflow Capacities

100 Mesh	150 Mesh	200 Mesh
2,700 GPM	1,300 GPM	750 GPM

Raking and Overflow Capacity Table

Capacity	Screw Speed	Spiral Speed	Minimum Motor HP Required
350 TPH	100%	17 RPM	20
260 TPH	75%	13 RPM	15
170 TPH	50%	9 RPM	10
90 TPH	25%	5 RPM	7.5

Percent Screw Speed Vs. Percent Fines In Product

Screw Speed	% Passing (50 Mesh)	% Passing (100 Mesh)	% Passing (200 Mesh)
100%	15	2	0
75%	20	5	0
50%	30	10	3
25%	50	25	8

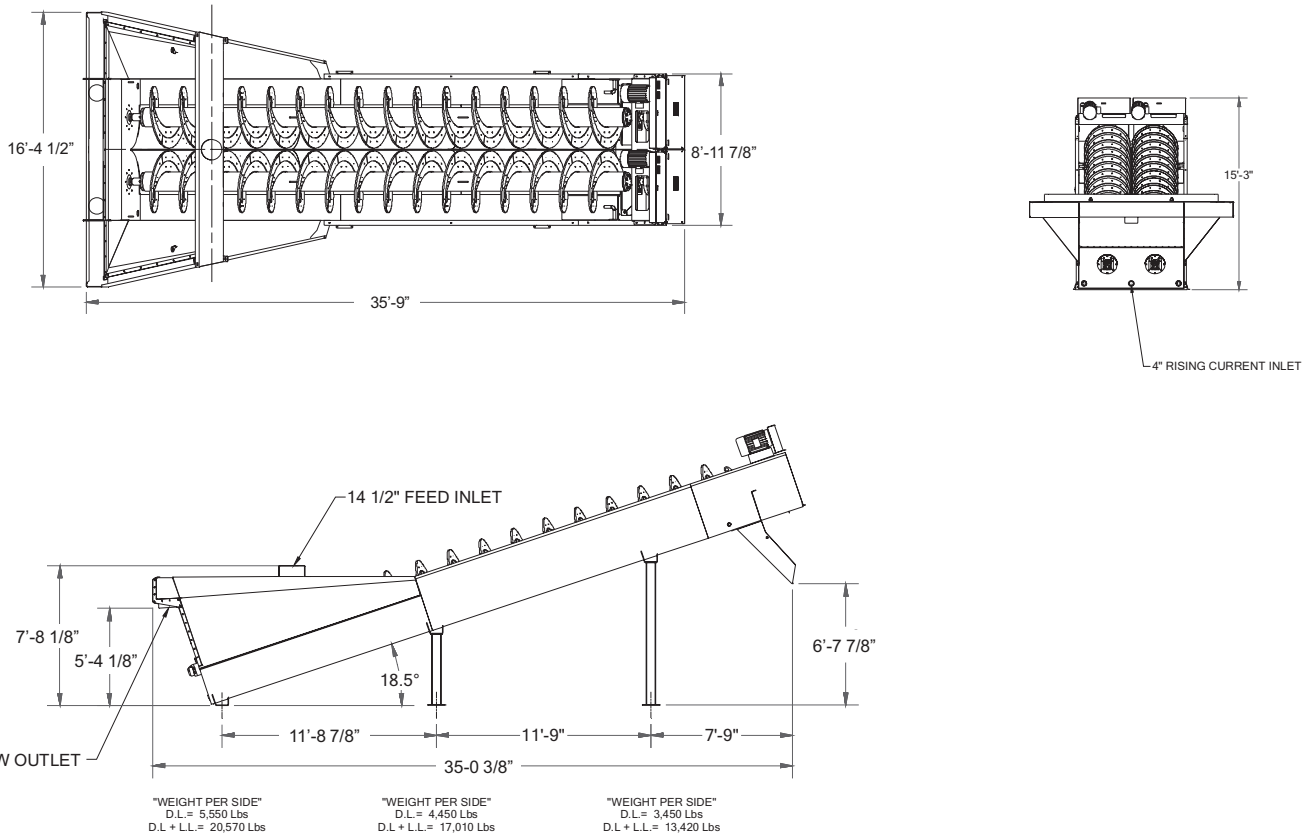

Kolberg-Pioneer, Inc.
 700 West 21st Street,
 Yankton, SD 57078
 1 (800) 542-9311
 mail@kpijci.com
 www.kpijci.com

NOTE: CONSULT FACTORY FOR EXACT DIMENSIONS, specifications are subject to change without notice.

Because Kolberg-Pioneer, Inc., Johnson Crushers International, Inc. and Astec Mobile Screens, Inc. may use in their catalog and literature, field photographs of their products which may have been modified by the owners, products furnished by Kolberg-Pioneer, Inc., Johnson Crushers International, Inc. and Astec Mobile Screens, Inc. do not warrant or represent that their products meet any federal, state, or local statutes, codes, ordinances, rules, standards or other regulations, including OSHA and MSHA, covering safety, pollution, electrical wiring, etc. Compliance with these statutes and regulations is the responsibility of the user and will be dependent upon the area and the use to which the product is put by the user. In some photographs, guards may have been removed for illustrative purposes only. This equipment should not be operated without all guards attached in their normal position. Placement of guards and other safety equipment is often dependent upon the area and how the product is used. A safety study should be made by the user of the application, and, if required additional guards, warning signs and other safety devices should be installed by the user, wherever appropriate before operating the products.

Rev: 3/19