

# 2500EVT

Wheel-Mounted Vertical Shaft Impactor Plant



## Impact Crusher - VSI

- Fully replaceable bolt on liners for tub, pedestal, and lid
- Feed box with externally adjustable feed tube
- 11 3/8" (289mm) feed diameter
- Hinged access doors in lid
- Roller bearing pedestal assembly
- 5 HP pedestal lubrication system with electric pump
- Oil alarm and cooling system
- Vibration monitor
- Application specific internal configurations
- Max feed size rotor = 2" (51mm)
- Max feed size shoe table = 3" (76mm)
- Accelerator speed = 700 to 1400 RPM

## End Delivery Conveyor

- 42" fixed height with full spill boards and cover
- Belt cleaner and discharge hood
- Screw take-up belt tension
- 10hp TEFC electric motor

## Chassis

- 32-TEC frame with tandem rear axle
- Rear crib legs and king pin support
- Eight 11:00 x 22.5 dual mounted tires
- Air brakes, travel lights, mudflaps
- Service platforms with ladder
- Crusher discharge chute

## Options

- Hard Parts (H) / Standard configuration including 3, 4, or 5 shoe impellor table and anvil cluster ring
- Semi-Autogenous (SA) configuration including 3 port rotor and anvil cluster ring
- Autogenous (A) configuration including 3 port rotor and hybrid rock shelf with anvils
- V-belt drive for electric motor with motor mount, crusher sheave, motor sheave, and v-belts
- 150 HP TEFC twin electric motors at 1200 RPM
- 200 HP TEFC twin electric motors at 1200 RPM
- Starter and 60' of cable for electric motor and 5 HP lube pump in NEMA-12 panel box
- Variable Frequency Drive (VFD) for crusher motor speed control
- 250 HP or 300 HP single electric motor (EV)
- Hydra arm lid removal system includes power lift and manual rotate for service
- Lube oil tank heater
- Belt scale
- Mid-point dust suppression spray bar
- Remote grease for conveyor head and tail pulley
- Transport bracket for spare / optional internal configuration components

## Physical/Operating Characteristics

Dimension	Standard	Metric
Operating Length	41' 11"	12.8m
Travel Length	41' 11"	12.8m
Operating Height	13' 5"	4.1m
Travel Height	12' 2"	3.7m
Ground Clearance	15"	0.3m
Total Weight (250 HP motors)	50,000 lb.	22,680 kg
End Delivery Conveyor	4,030 lb.	1,828 kg
Feed Hopper	250 lb.	114 kg
Operating Width (approx panel)	14' 6"	3.8m

Dimension	Standard	Metric
Travel Width	11' 6"	3.5m
Feed Height	13' 5"	4.1m
Discharge Height	6' 2"	1.9m
Service Width (lid open)	15' 8"	4.8m
Service Height (lid open)	14' 6"	4.4m
Basic Motor Controls & Panel	800 lb.	363 kg
250 HP Electric Motor & Mount	5,490 lb.	2,490 kg
300 HP Electric Motor & Mount	5,950 lb.	2,700 kg

Travel Mode

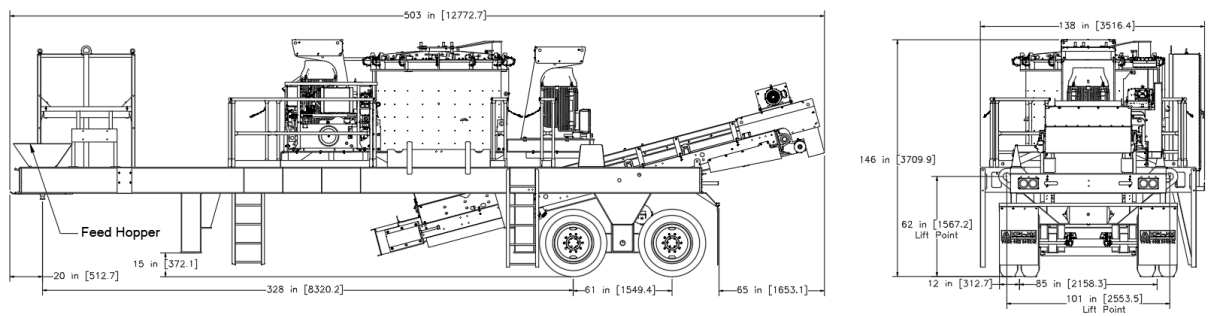

Operation Mode

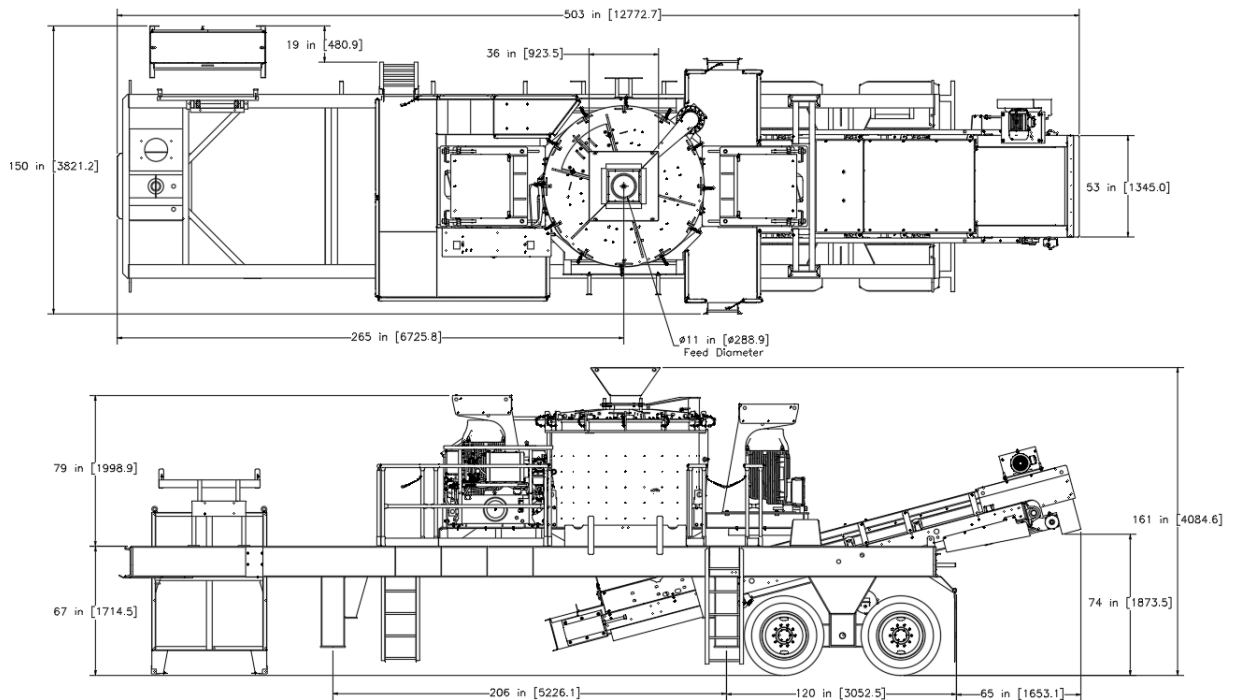

Kolberg-Pioneer, Inc.  
700 West 21st Street,  
Yankton, SD 57078  
1 (800) 542-9311  
mail@kpijci.com  
www.kpijci.com

**NOTE: CONSULT FACTORY FOR EXACT DIMENSIONS, specifications are subject to change without notice.**

Because Kolberg-Pioneer, Inc., Johnson Crushers International, Inc. and Astec Mobile Screens, Inc. may use in their catalog and literature, field photographs of their products which may have been modified by the owners, products furnished by Kolberg-Pioneer, Inc., Johnson Crushers International, Inc. and Astec Mobile Screens, Inc. do not warrant or represent that their products meet any federal, state, or local statutes, codes, ordinances, rules, standards or other regulations, including OSHA and MSHA, covering safety, pollution, electrical wiring, etc. Compliance with these statutes and regulations is the responsibility of the user and will be dependent upon the area and the use to which the product is put by the user. In some photographs, guards may have been removed for illustrative purposes only. This equipment should not be operated without all guards attached in their normal position. Placement of guards and other safety equipment is often dependent upon the area and how the product is used. A safety study should be made by the user of the application, and, if required additional guards, warning signs and other safety devices should be installed by the user, wherever appropriate before operating the products.