

Washing and Classifying

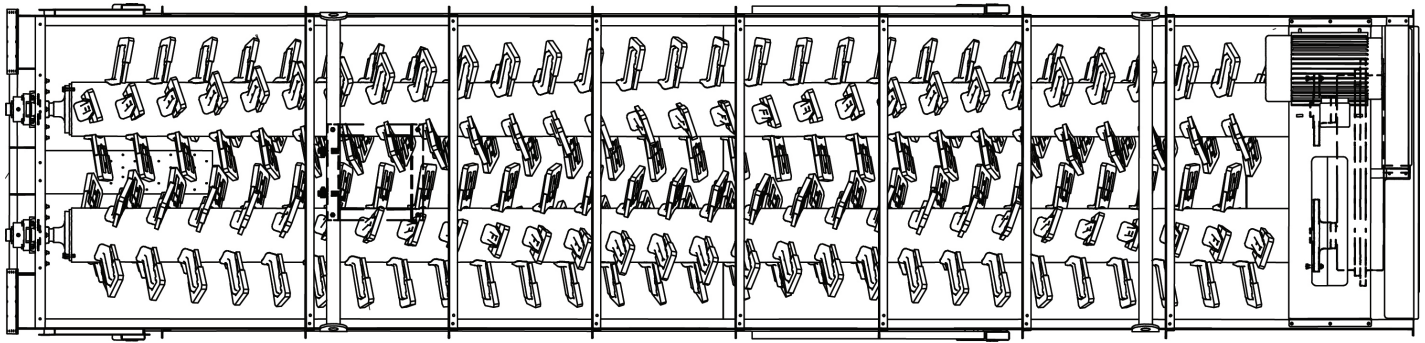

Log Washers

Even the most agglomerated deposits are no match for our innovative log washers. Our exclusive reverse involution design has paddles arranged in a spiral pattern along the shaft, producing a much more effective scrubbing action to remove tough, plastic-soluble clays and other unwanted coatings. This unique motion ensures that some portion of material is constantly moving, leveling power demand while reducing power consumption.



Reverse Involution

Our exclusive reverse involution spiral paddle arrangement provides increased tons per hour per horsepower while producing cleaner products. This design also reduces intermittent shock loading for longer service life, keeps a portion of the mass in motion at all times for reduced energy requirements, and increases retention time for effective scrubbing. Over the life of the unit, these design benefits could provide more than \$40,000 in savings over comparable models.

Durable Wear Parts

Heavy-duty, adjustable cast ni-hard inner and outer paddle tips include a corrugated face, which provides increased scrubbing effectiveness, superior wear parts life, reduced wear parts cost and improved safety.

Heavy-Duty Tub Design

Heavy-duty, steel plate construction provides years of leak-free operation, increasing longevity.

Large Clean-Out Ports

Large clean-out ports ensure ease of maintenance and reduce operating costs.



Skid Base

Our log washers are available with optional skid base with angle of operation adjustment.



Model	Spiral Diameter		Capacity		Water Required	
	Inches	Millimeters	TPH	MTPH	USGPM	LPM
8024-18	24	610	25 - 80	22 - 73	25 - 250	95 - 950
8036-30	36	914	85 - 200	77 - 181	50 - 500	190 - 1,900
8048-30	48	1,219	125 - 300	113 - 272	100 - 800	380 - 3,030
8048-35	48	1,219	125 - 400	113 - 363	100 - 800	380 - 3,030

Available as

 Portable
  Stationary

Coarse Material Washers

Our coarse material washers are engineered to quickly adapt to producers' ever-changing needs. Both single- and twin-spiral designs can be easily reconfigured with numerous bolt-on paddle and flight arrangements to satisfy even the most precise specifications. Our coarse material washers are equipped with our high-efficiency drive and offer a throughput of 500 STPH for increased productivity.

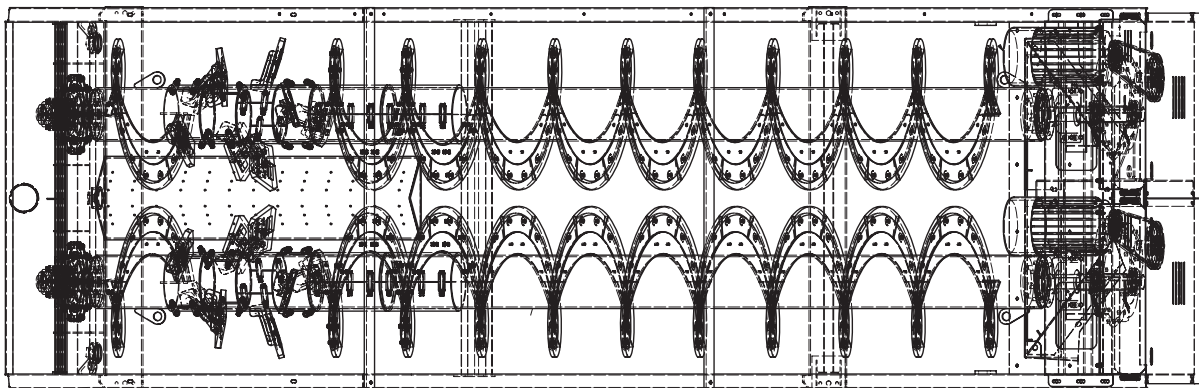

Adjustable Configuration

Interchangeable bolt-on paddle and flight assemblies in the scrubbing zone allow the user to configure the unit for adjustable capacity, adjustable scrubbing action and maximum efficiency in any application.

Weir Boards

Adjustable, full-width overflow weir boards and collecting flume handle large volumes of slurry and control pool depth for uniform overflow.

Efficient Drive Assembly

Highly efficient and reliable drive assembly reduces horsepower requirements, decreasing operating costs.

Integral Rising Current Manifold

Integral rising current manifold creates a rising current, ensuring material separation for maximum deleterious material removal.

Large Clean-Out Ports

Large clean-out ports ensure ease of maintenance and reduce operating costs.

Durable Wear Parts

Cast ni-hard, two-piece paddle tips with a corrugated face increase scrubbing effectiveness and wear life. Cast ni-hard outer wear shoes reduce operating costs by providing maximum wear life in most applications. Standard AR steel inner wear shoes protect the entire flight, eliminating expensive downtime and repairs.

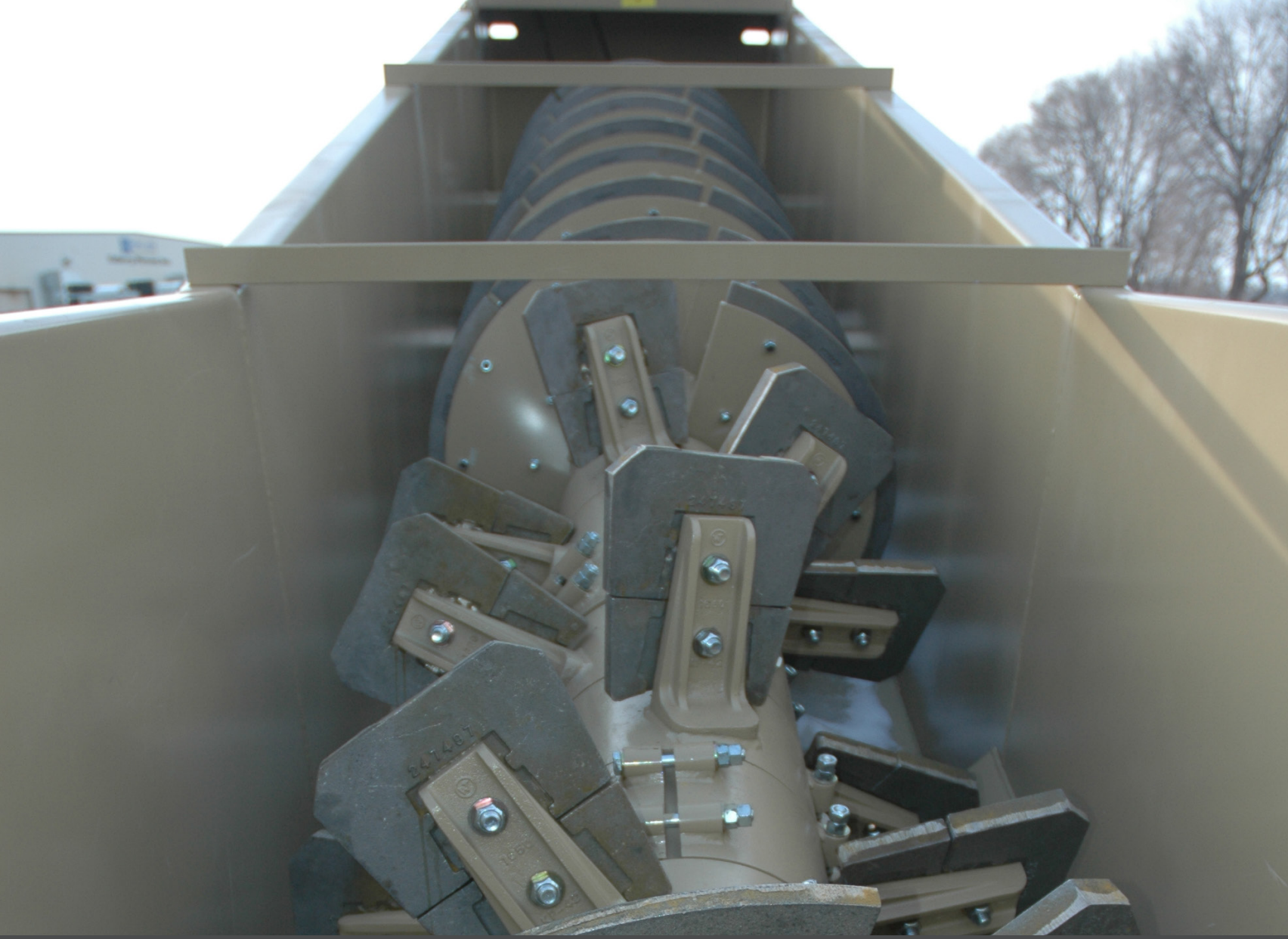

Model	Spiral Diameter		Capacity		Water Requirements	
	Inches	Millimeters	TPH	MTPH	USGPM	LPM
6024-15S	24	610	60 - 75	54 - 68	300 - 400	1,135 - 1,515
6036-19S	36	914	150 - 175	137 - 159	400 - 600	1,515 - 2,270
6036-19T	36	914	300 - 350	272 - 318	700 - 900	2,650 - 3,405
6048-23S	48	1,219	200 - 250	181 - 227	500 - 700	1,890 - 2,650
6048-23T	48	1,219	400 - 500	363 - 454	800 - 1,000	3,030 - 3,785

S=Single Spiral T=Twin Spiral

Available as



Portable



Stationary

Blademills

Our blademills are designed for seamless compatibility with producers' existing processing plants. The innovative double-pitch flights and ribbed-paddle design efficiently convey material through the blademill to break up sticky clay and muddy clumps with extraordinary effectiveness. Almost all of the bolt-on ni-hard paddles and spiral flights are adjustable to best match your aggregate production needs.

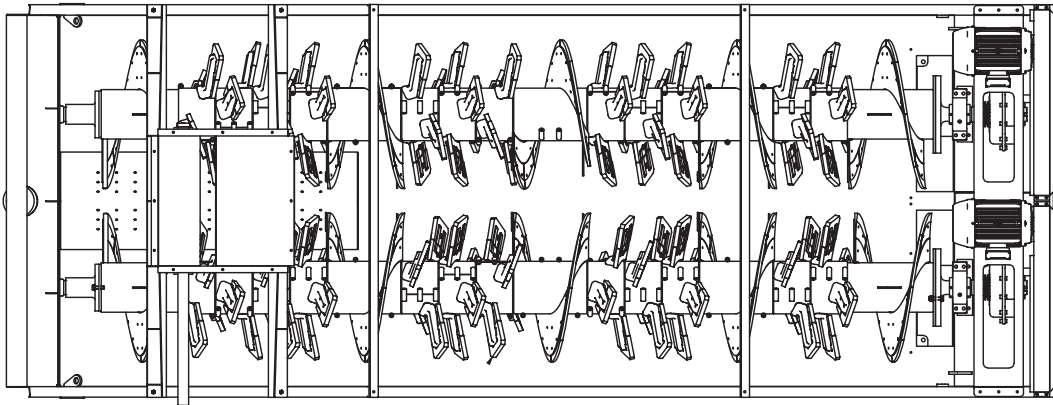

Adjustable Configuration

Interchangeable bolt-on paddle and flight assemblies throughout the length of the unit allow producers to configure the unit for adjustable capacity, adjustable scrubbing action and maximum efficiency in any application.

Durable Wear Parts

Cast ni-hard two-piece paddle tips with a corrugated face increase scrubbing effectiveness and wear life. Standard cast ni-hard outer wear shoes and AR steel inner wear shoes increase longevity and reduce operating costs.

Feed Box with Header Pipe

The blademill's feed box with header pipe ensures material is slurried prior to entering the unit for maximum scrubbing and increased cleanliness.

Efficient Drive Assembly

Highly efficient and reliable drive assembly reduces horsepower requirements, decreasing operating costs.

Integral Rising Current Manifold

Integral rising current manifold creates a rising current, ensuring material separation for maximum deleterious material removal.

Large Clean-Out Ports



Large clean-out ports ensure ease of maintenance and reduce operating costs.



Model	Spiral Diameter		Capacity		Water Requirements	
	Inches	Millimeters	TPH	MTPH	USGPM	LPM
6524-15S	24	610	60 - 75	54 - 68	75 - 150	280 - 560
6536-19S	36	914	150 - 175	137 - 159	100 - 200	380 - 760
6536-19T	36	914	300 - 350	272 - 318	175 - 350	660 - 1,320
6548-23S	48	1,219	200 - 250	181 - 227	125 - 250	470 - 940
6548-23T	48	1,219	400 - 500	363 - 454	200 - 400	760 - 1,520

S=Single Spiral T=Twin Spiral

Available as

Portable Stationary

Fine Material Washers

Our fine material washers deliver extreme productivity when and where producers need it. Engineered with high-efficiency drives, the resulting low-horsepower requirement reduces operating costs while increasing throughput, ensuring your operation runs efficiently and profitably.

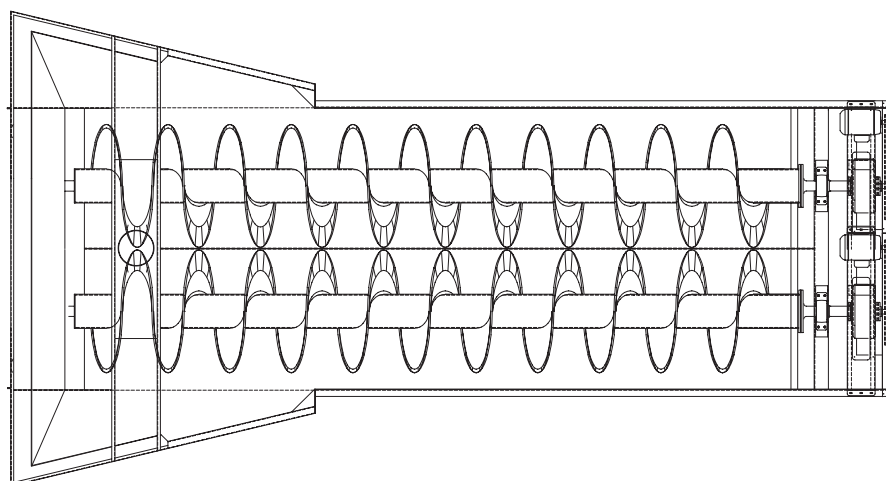

Efficient Drive Assembly

High-efficiency v-belt drive assembly reduces horsepower and maintenance, resulting in increased life and reduced operating costs. Standard high-efficiency Dodge® reducers and bearings are readily available and easily accessible for ease of maintenance.

Shaft Speed

Shaft speed is changed via a simple sheave change, allowing the user to match the screw speed to the application, ensuring maximum efficiency.

Heavy-Duty Tub Design with Baffled Feed Box

Heavy-duty steel plate construction provides years of leak-free operation, increasing longevity. Internal and external baffles in feed box, coupled with a large pool area, provide maximum fines retention, resulting in a more marketable product.

Adjustable Weirs

Adjustable overflow weir boards and collecting flume allow precise control of the overflow slurry, allowing producers to meet tight specifications, resulting in more profit per ton processed.

Integral Rising Current Manifold

Integral rising current manifold creates a rising current, ensuring material separation for maximum deleterious material removal.

Durable Wear Parts

Standard urethane outer wear shoes and AR steel inner wear shoes increase longevity and reduce operating costs. Optional cast ni-hard outer wear shoes are available for highly-abrasive manufactured sand applications.



Model	Spiral Diameter		Maximum Raking Capacity		Maximum Overflow Capacity	
	Inches	Millimeters	TPH	MTPH	USGPM	LPM
5024-25S	24	610	50	45	500	1,890
5030-25S	30	762	75	68	550	2,080
5036-25S	36	914	100	91	700	2,650
5036-25T	36	914	200	182	1,200	4,540
5044-32S	44	1,118	175	159	1,500	5,680
5044-32T	44	1,118	350	318	2,700	10,220
5048-32S	48	1,219	200	182	1,650	6,245
5048-32T	48	1,219	400	364	2,900	10,980
5054-34S	54	1,372	250	227	1,800	6,815
5054-34T	54	1,372	500	454	3,200	12,110
5060-35S	60	1,524	325	295	2,200	8,330
5060-35T	60	1,524	650	590	3,600	13,630
5066-35S	66	1,676	400	364	2,400	9,085
5066-35T	66	1,676	800	728	4,000	15,140
5072-38S	72	1,829	475	431	2,600	9,840
5072-38T	72	1,829	950	862	4,400	16,655

Available as



Portable



Stationary

S=Single Spiral T=Twain Spiral

Classifying Tanks

Our industry-leading classifying tanks are engineered to maximize profitability. The process begins with our Spec Select® Windows-based controllers and 24-volt DC bridge design, which allow simple control of the products, system monitoring and reporting features right from the controller. The patented design eliminates internal tank support members, creating less turbulence and more accurate settling of the feed material. Available in sizes from 8' x 20' up to 12' x 48', these systems are unmatched by anything the industry has to offer.

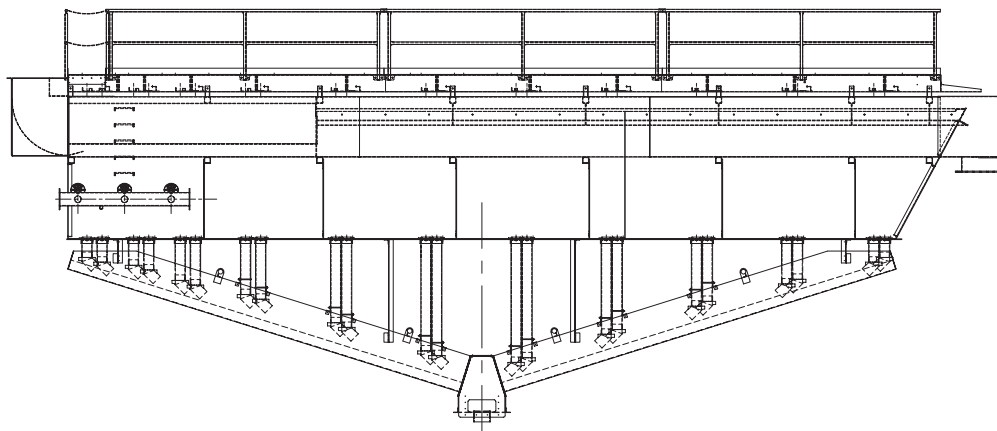

Patented Tank Construction

Our self-supporting tank design allows for flexibility in position of the dewatering equipment under the classifying tank. The lack of internal stiffeners reduces turbulence and greatly increases settling efficiency, resulting in more efficient gradation splits, improved material utilization and more profit per ton processed.

Durable Wear Parts

Standard self-aligning urethane dart valves and standard snap-in urethane valve seats ensure uniform flow at the maximum rate, positive sealing and long service life. The unique design of the urethane discharge elbows allows maximum flow at the optimum angle, reducing unwanted material spillage and reducing wear on the elbow and in the collecting flume.

24-Volt DC Bridge Operation

All hydraulic plumbing is stainless steel tubing with O-ring face seal fittings and a 3-year leak-free guarantee for improved service life and a leak-free operation. 24-volt DC operation provides enhanced monitoring and troubleshooting capabilities in real time while providing more reliable control and operation than conventional 120-volt AC systems.

User-Friendly Control System

Windows-based programming ensures that the Spec Select® controllers are the most user-friendly controllers on the market. The standard Dell PC HMI includes the monitor, CPU, keyboard and optical mouse. An optional industrial PC HMI housed in a NEMA 4 enclosure is available for outdoor installations.

Optional Configurations

Stationary, skid/semi-portable or portable plants available.

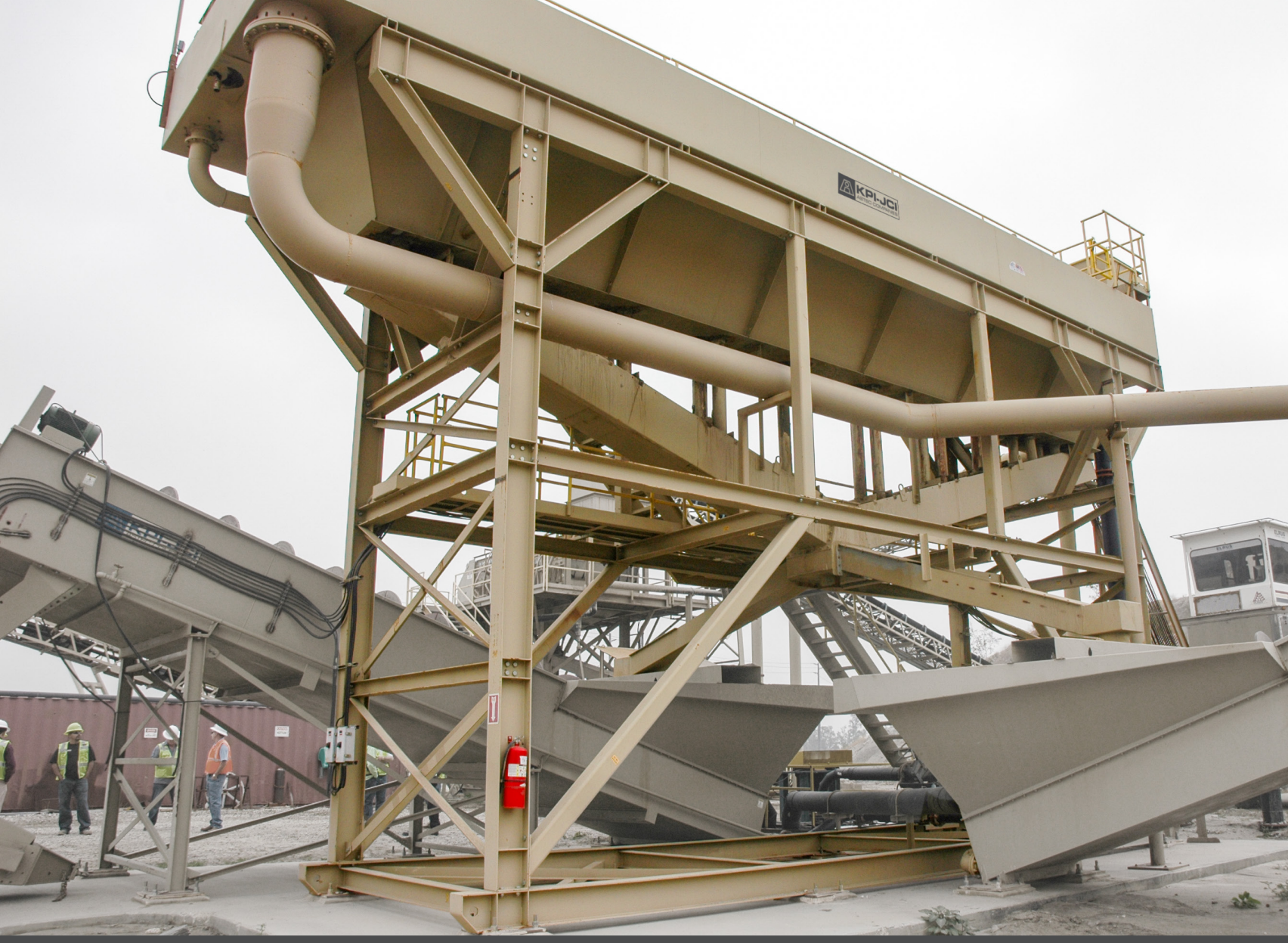

Model	Tank Width		Tank Length		Maximum Overflow Capacity	
	Feet	Meters	Feet	Meters	USGPM	LPM
7008-20	8	2.4	20	6	2,300	8,705
7008-24	8	2.4	24	7.3	2,800	10,600
7008-28	8	2.4	28	8.5	3,200	12,115
7008-32	8	2.4	32	9.8	3,500	13,250
7010-24	10	3	24	7.3	3,500	13,250
7010-28	10	3	28	8.5	4,100	15,520
7010-32	10	3	32	9.8	4,700	17,790
7010-36	10	3	36	11	5,300	20,060
7010-40	10	3	40	12	5,900	22,335
7012-48	12	3.6	48	14.6	8,100	30,660

Available as



Portable



Stationary

Screening/Washing Plants

Efficiently process aggregate material wherever opportunities exist with our portable Series 1800 screening and washing plants. Our Series 1800 plants offer our industry-leading fine material washer with an array of configurations – choose inclined or horizontal wet single-, double- or triple-shaft screens with two or three decks and even add a blademill – all on a single chassis. Standard and custom-built skid-mounted or stationary plants are available with an unlimited number of configurations and options to meet any application.

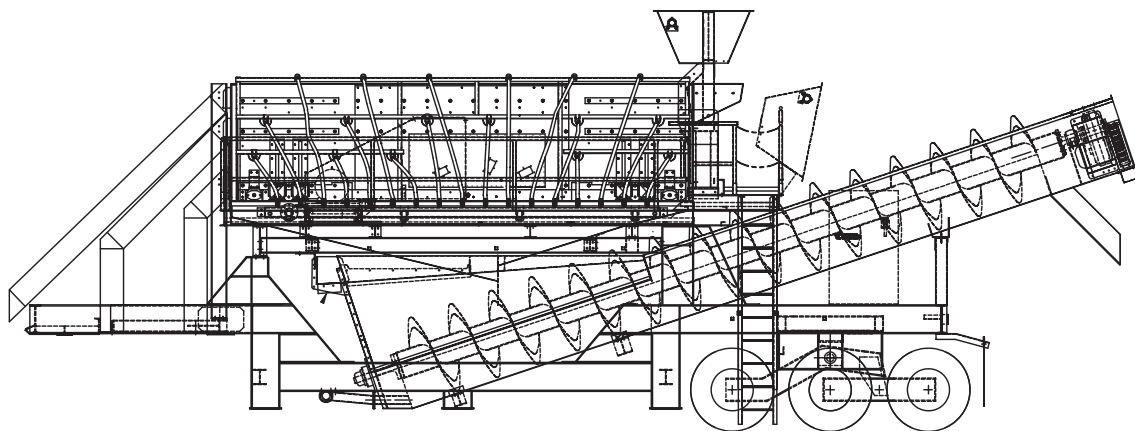

Single Source

As the only American manufacturer that builds all of the equipment in its plants, we are uniquely qualified to be a single-source provider for all of your processing needs. We also offer a full line of support equipment, including hopper/feeders, conveyors, crushers and electrical packages.

Innovation

Our patented PHB models are the largest portable plants offered by any American manufacturer, providing unsurpassed capacity and producing cleaner, higher-quality products. These self-contained, self-erecting plants reduce set-up and tear-down time, resulting in more uptime and increased profits.



Unique Options

Optional features include roll-away screen chutes that provide access to screen cloth for increased ease of maintenance, blending gates for guaranteed in-spec products, and cross-conveyors for larger stockpiles and placement flexibility.



Model	Screen Size		Fine Material Washer Size		Blademill Size	
	Feet	Meters	Inches x Feet	Millimeters x Meters	Inches x Feet	Millimeters x Meters
1814	5 x 14 (incline)	1.5 x 4.2 (incline)	36 x 25 (single)	914 x 7.6 (single)	-	-
1822	6 x 16	1.8 x 4.9	36 x 25 (twin)	914 x 7.6 (twin)	-	-
1822PHB	6 x 16 (horizontal)	1.8 x 4.9 (horizontal)	36 x 25 (twin)	914 x 7.6 (twin)	24 x 12 (twin)	610 x 3.7 (twin)
1830	6 x 20	1.8 x 6.0	44 x 32 (twin)	1,118 x 9.8 (twin)	-	-
1830PHB	6 x 20 (horizontal)	1.8 x 6.0 (horizontal)	44 x 32 (twin)	1,118 x 9.8 (twin)	36 x 15 (twin)	914 x 4.6 (twin)

Available as

 Portable
  Stationary

Dewatering Screens

Our dewatering screens dewater sand products to a level typically not possible with fine material washers. Depending on product gradation and other material characteristics, our dewatering screens will produce material with a moisture content as low as 8%. Our single-deck, adjustable-incline, linear-motion screens are available in sizes ranging from 2' x 7' to 8' x 16' with processing rates up to 400 STPH on a single unit.

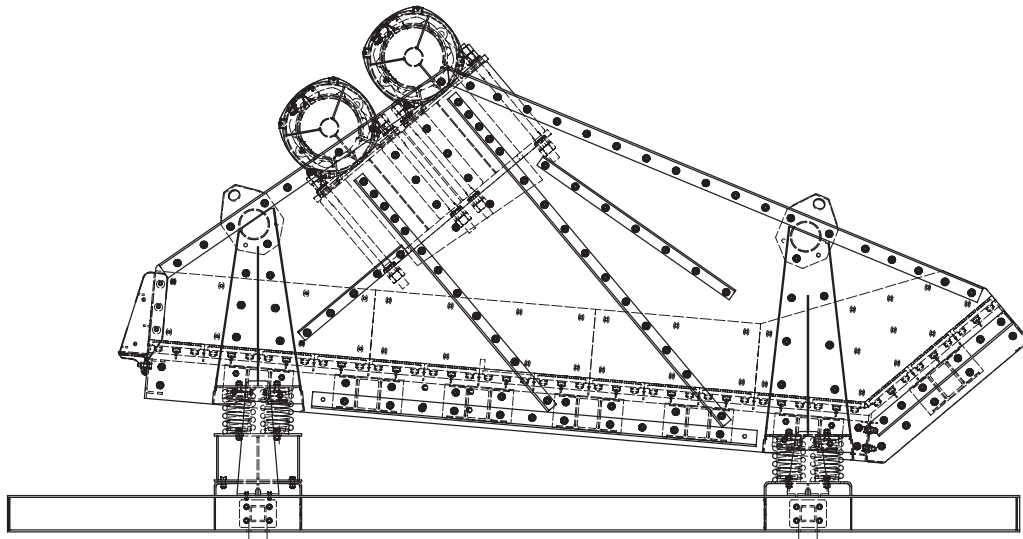

Fabricated Motor Bridge

Our stress-relieved, fabricated motor bridge with engineered motor-mounting studs increases equipment lifespan and reduces operating costs.

Bolted Screen Assembly

A predominately-bolted screen frame assembly features integral stiffener tubes and lifting lugs for increased durability and long life.

Polydeck® Media

Our dewatering screens utilize abrasion-resistant 1' square x 30 millimeters thick modular urethane Polydeck® screen media with slotted apertures for increased reliability and availability.

Side Liners

Bolt-in UHMW pan side liners protect pan sides from premature wear.

Application Flexibility

Adjustment of the angle of inclination, motor stroke, discharge dam height and media opening sizes allow the unit to be configured for most applications, ranging from production of a coarse concrete sand to dewatering of waste fines from the effluent stream of a wash plant.



Model	Power		Capacity* (-#50 x +#325)		Capacity* (-#4 x +#150)	
	HP	kW	TPH	MTPH	TPH	MTPH
DWS 27	2 at 2.7	2 at 2.0	13	12	43	39
DWS 38	2 at 3.9	2 at 2.9	20	18	65	59
DWS 410	2 at 4.7	2 at 3.5	43	39	144	131
DWS 513	2 at 8.4	2 at 6.3	65	59	216	196
DWS 613	2 at 9.4	2 at 7.0	78	71	259	235
DWS 716	2 at 15.4	2 at 11.5	106	96	353	321
DWS 816	2 at 15.4	2 at 11.5	121	110	403	366

*Assumes a 2.67 S.G.

*Capacities provided are estimates only. Consult factory for specific applications.

Available as



Portable



Stationary

Series 9000 Plants

Our Series 9000 products are custom-engineered and built for each application, ensuring equipment performs as intended from initial commissioning through its production life. Products include classifying cyclones, dewatering screens, dewatering cyclones, pumps, attrition cells, density classifiers and sieve bend screens. Unlike some manufacturers, we focus on building customized systems that deliver the highest return for the producer. The Series 9000 family of products can be used as a stand-alone system or combined with traditional systems.

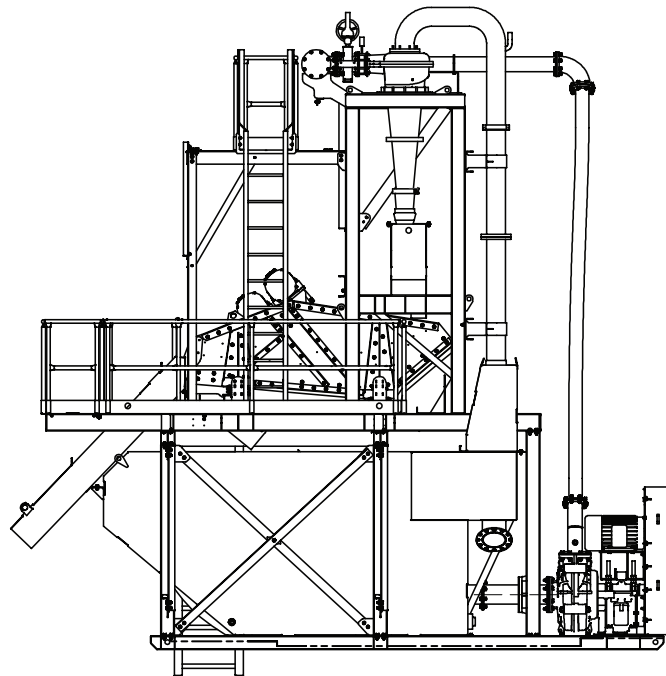

Model #9400 Plant

Our Model #9400 plants are designed for aggregate producers requiring a fines recovery plant to support their existing operations by reducing the volume of fine material reporting to the settling pond.

Model #9200 Plant

The Model #9200 plants are designed to dewater and fine-tune sand products to a level typically not possible with traditional sand-dewatering equipment. Custom-built plants are available in portable, semi-portable and stationary configurations with various types and quantities of cyclones and various pump and dewatering screen sizes.

Complete Package

Series 9000 plants include a dewatering screen, cyclone, slurry pump and custom-engineered chassis or skid-mounted support structure.

Application Flexibility

Applications may include production of specialty sands such as frac sand, foundry sand, glass sand or golf course sands, fines recovery, and removal of deleterious material such as lignite (coal) or organics from an otherwise-acceptable sand product.

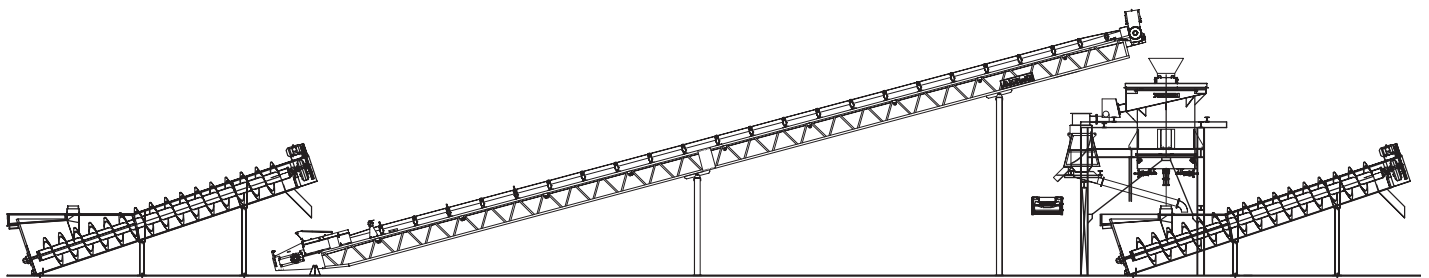

Lignite (Coal) Removal System

Available as



Portable



Stationary

Complete Systems

Our complete systems incorporate industry-leading products into a single, custom-engineered system created to your exact specifications. Our team of engineers and industry experts partner with you on everything from plant design to component manufacturing, site layout, installation and lifetime product support. Every operational requirement is taken into consideration to ensure a plant that exceeds expectations.

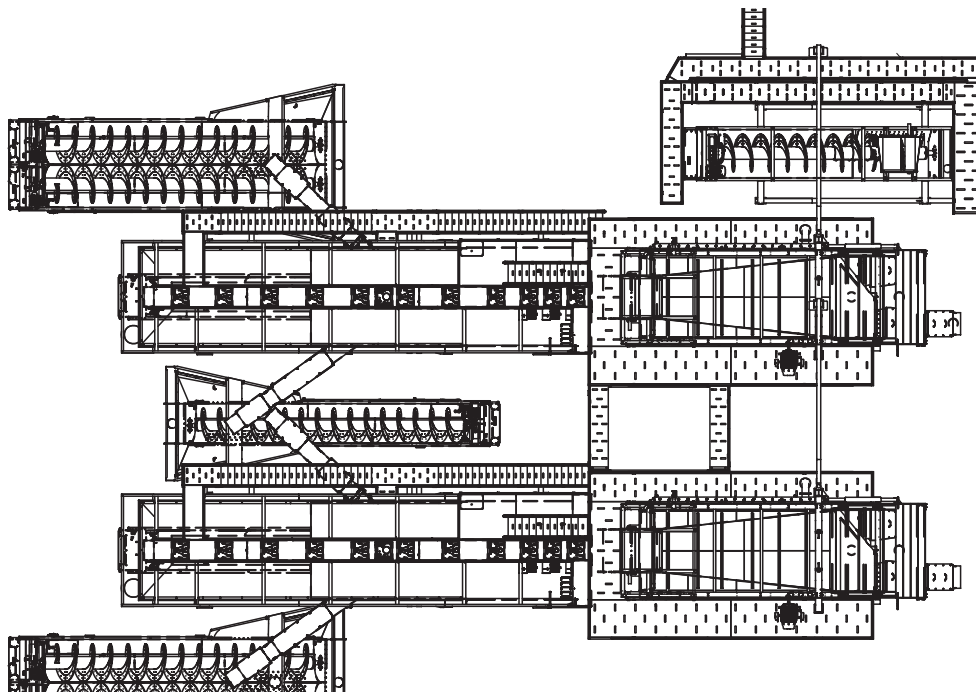

Custom-Engineered

Custom-engineered and manufactured systems are capable of meeting the most demanding plant or product specifications.

Single Source

Single source responsibility includes crushing, screening, washing and classifying, material handling, electrical and structural components.

Complete Offering

We offer the largest, most complete offering of aggregate processing equipment obtainable from a single-source manufacturer. No single distribution network provides a more complete source for sales, parts and service.

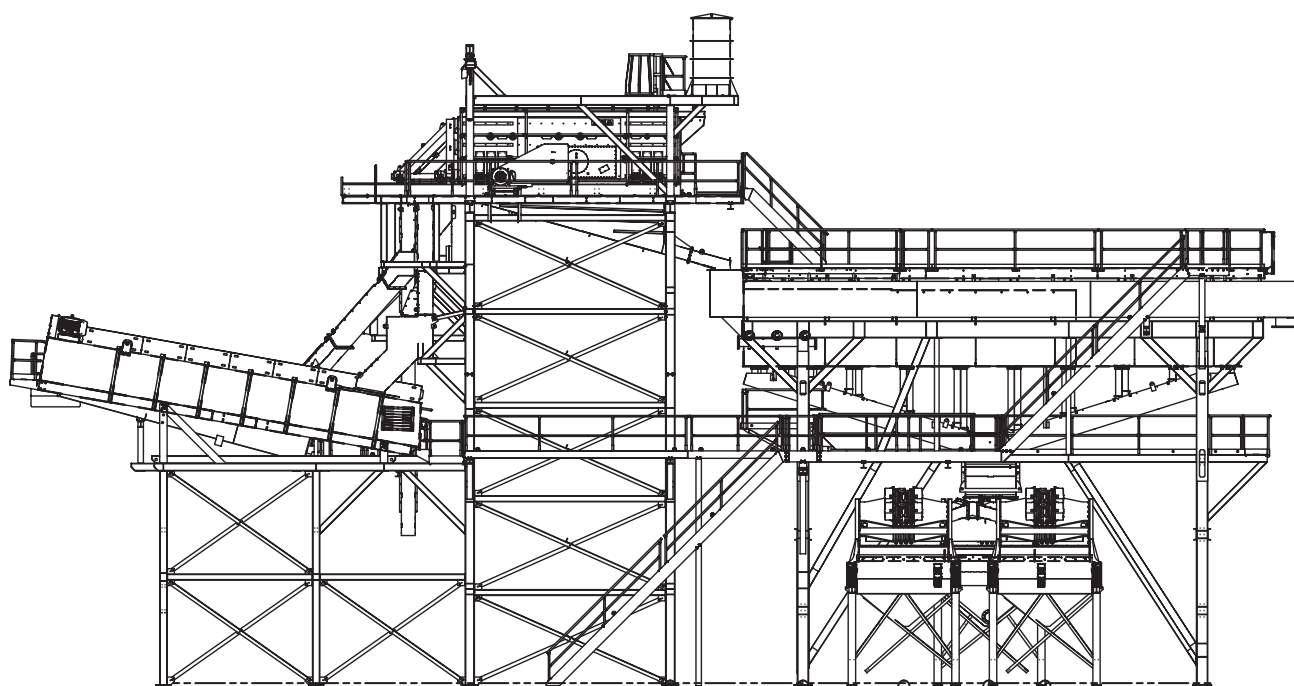

Water Clarification

Our complete systems incorporate industry-leading products into a single, custom-engineered system created to your exact specifications. Our team of engineers and industry experts partner with you on everything from plant design to component manufacturing, site layout, installation and lifetime product support. Every operational requirement is taken into consideration to ensure a plant that exceeds expectations.

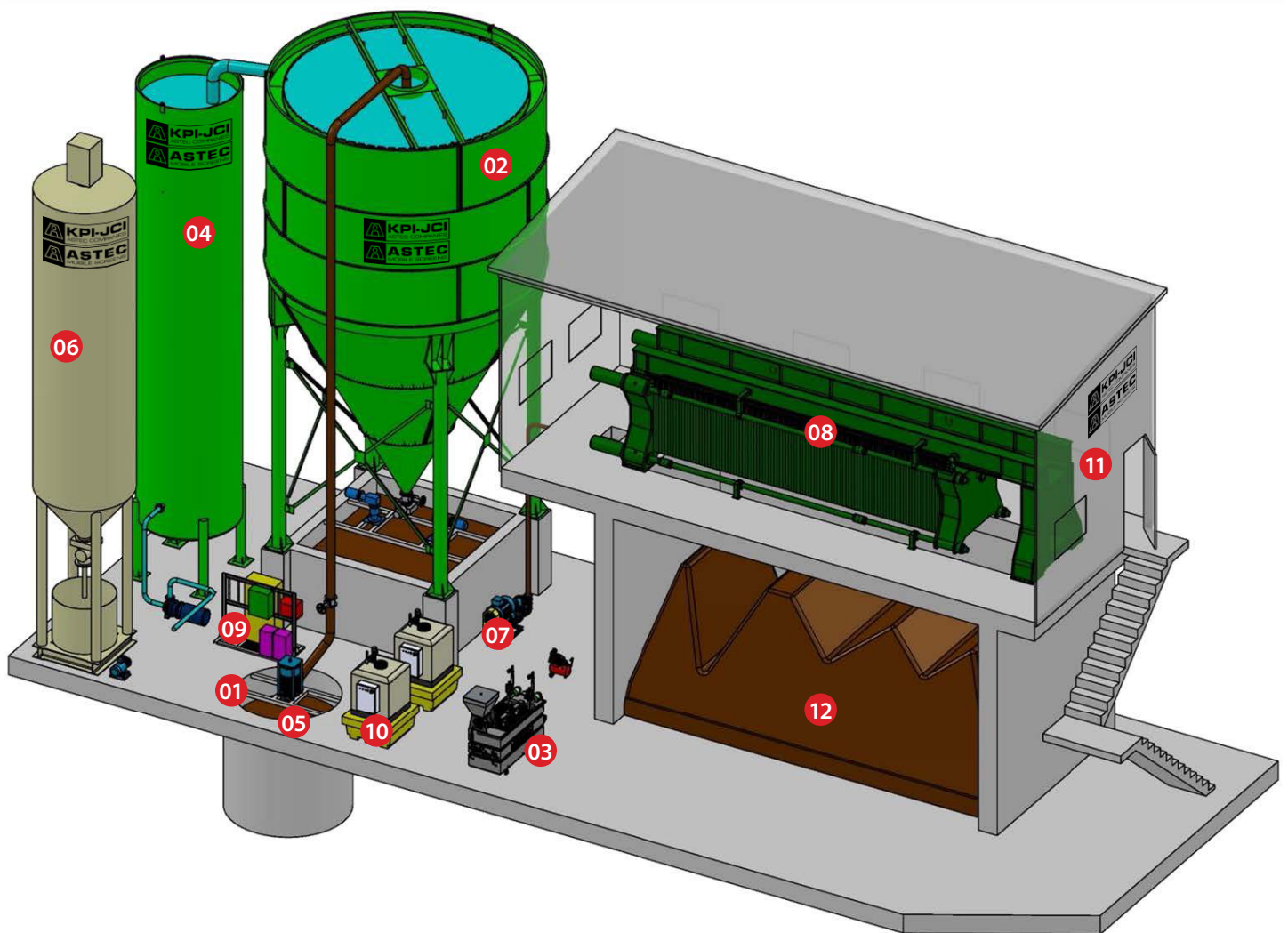



- 01 Waste Water Pit And Pumps
- 02 Static Vertical Settling Tank
- 03 Tecnoidea Flocculant Station
- 04 Clarified Water Tank
- 05 Thickened Sludge Tank
- 06 Sludge Conditioning

- 07 Thickened Sludge Pump
- 08 Tecnoidea Plate Press
- 09 Tecnoidea Water Neutralization Unit
- 10 Chemical Conditioning
- 11 Housing
- 12 Dehydrated Sludge



Kolberg-Pioneer, Inc.

700 West 21st Street
Yankton, SD 57078 USA
P: (800) 542-9311 | (605) 665-9311
F: (605) 665-8858

Johnson Crushers International, Inc.

86470 Franklin Boulevard
Eugene, OR 97405 USA
P: (800) 314-4656 | (541) 736-1400
F: (541) 736-1424

Astec Mobile Screens, Inc.

2704 West LeFevre Road
Sterling, IL 61081 USA
P: (800) 545-2125 | (815) 626-6374
F: (815) 626-6430

www.kpijci.com

Because Kolberg-Pioneer, Inc., Johnson Crushers International, Inc. and Astec Mobile Screens, Inc. may use in their catalog and literature, field photographs of their products which may have been modified by the owners, products furnished by Kolberg-Pioneer, Inc., Johnson Crushers International, Inc. and Astec Mobile Screens, Inc. may not necessarily be as illustrated therein. Also continuous design progress makes it necessary that specifications be subject to change without notice. All sales of the products of Kolberg-Pioneer, Inc., Johnson Crushers International, Inc. and Astec Mobile Screens, Inc. are subject to the provisions of their standard warranty. Kolberg-Pioneer, Inc., Johnson Crushers International, Inc. and Astec Mobile Screens, Inc. do not warrant or represent that their products meet any federal, state, or local statutes, codes, ordinances, rules, standards or other regulations, including OSHA and MSHA, covering safety, pollution, electrical wiring, etc. Compliance with these statutes and regulations is the responsibility of the user and will be dependent upon the area and the use to which the product is put by the user. In some photographs, guards may have been removed for illustrative purposes only. This equipment should not be operated without all guards attached in their normal position. Placement of guards and other safety equipment is often dependent upon the area and how the product is used. A safety study should be made by the user of the application, and, if required additional guards, warning signs and other safety devices should be installed by the user, wherever appropriate before operating the products.

NOTE: SPECIFICATIONS ARE SUBJECT TO CHANGE WITHOUT NOTICE

Rev. 10/19