

Portable Plants

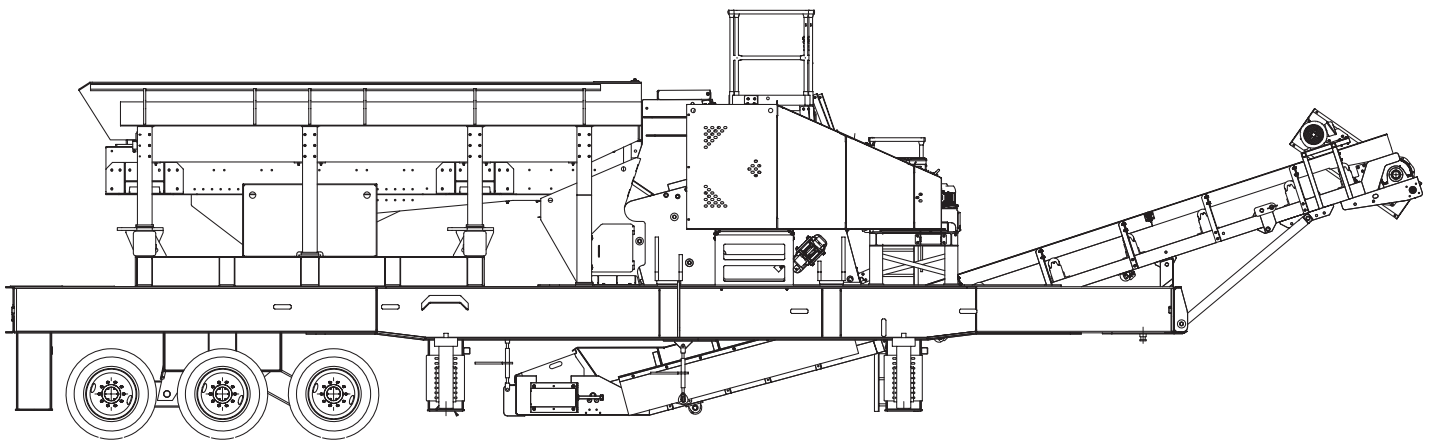

Pioneer® Jaw Crusher Plants

Our Pioneer® Series jaw crushing plants represent the very latest in jaw crusher technology. Engineered to be the highest capacity jaw crusher on the market, our portable Pioneer® jaw crushing plant will deliver up to 25% more tons per hour than other comparable plants. Pair that with heavy-duty flywheels for reduced horsepower requirements and class-leading stroke for higher capacity, and you have a machine that will help you squeeze every cent of profit out of your operation.



Large Flywheels

Large, dynamically-balanced flywheels reduce peak horsepower requirements and yield lower cost-per-ton product.

Class-Leading Stroke

The class-leading, 1½" stroke offers faster throughput for higher capacity.

Ease of Access

Easy access to all controls provides quick setup, smooth operation and simplified maintenance.

Durable Construction

Equipped with an I-beam frame, heavy-duty axles and AR-lined chutes, our portable Pioneer® jaw crushing plants are engineered for maximum durability and high resale value.

Portability

Our portable plants offer the same efficient and reliable performance as our stationary and track-mounted plants, and provide versatility for ideal application flexibility.



Model	Dimension (H x W x L)		Total Weight		Max. Feed Size		Capacity	
	Feet	Meters	Pounds	Kilograms	Inches	Millimeters	TPH	MTPH
CS2056	18.08 x 11.92 x 71	5.5 x 3.6 x 20.6	115,000	54,349	17	432	212 - 268	193 - 244
CS2650	18.08 x 11 x 67.42	5.5 x 3.4 x 20.6	119,820	54,349	21	533	268 - 325	243 - 295
CS3055	16.42 x 10.75 x 54.17	5 x 3.3 x 16.5	131,000	59,420	24	610	502 - 660	455 - 599
CS3144	16.5 x 11.02 x 49.25	5 x 3.4 x 15	104,400	47,355	25	635	405 - 533	367 - 484
CS3552	14.5 x 10.67 x 61.08	4.1 x 3.3 x 18.6	121,500	55,112	26	660	525 - 691	476 - 627
CS3365	17.83 x 11.45 x 57.5	5.4 x 3.5 x 17.5	160,734	72,907	26	660	761 - 969	692 - 882
VS4450	20.67 x 15 x 62.25	6.3 x 4.6 x 19	204,994	99,984	35	889	775 - 1,020	703 - 925

Available as



Track-Mounted



Portable



Stationary

Andreas HSI Plants

Accommodating three- or four-blow bar configurations, our portable Andreas Series Horizontal Shaft Impactor (HSI) plants offer the adaptability and capacity required to meet the fast-changing aggregate market. A large feed opening and a high-performance MPR rotor make these impact crushers well suited for recycle and aggregate processing applications. With up to 30% more uptime and 25% more production than competitive models, our portable Andreas Series HSI plants deliver exceptional performance.

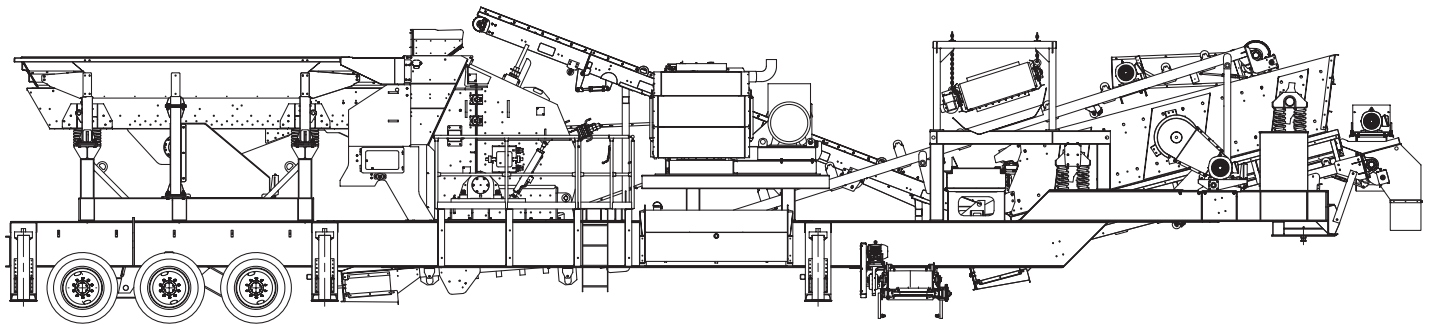

MPR Rotor

Our Andreas Series HSI plants can be configured with a 3- or 4-bar MPR Rotor*, creating a large reduction ratio ideal for operations where maximum performance is required.

Durable Construction

Equipped with an I-beam frame, heavy-duty axles and AR-lined chutes, our portable Andreas Series HSI plants are engineered for maximum durability and high resale value.

Plant Configuration

With a wide variety of options, including feeder sizes, belt width and axle configuration, our Andreas HSI plants can be configured to suit a large variety of demanding applications.

**ProSizer 3100 designed with a 2-bar MPR Rotor.*

Application Flexibility

Designed to be used in recycle concrete, recycle asphalt, aggregate quarrying and mining quarrying applications, our portable Andreas HSI plants offer exceptional flexibility for producers on the move.

Portability

Our portable plants offer the same efficient and reliable performance as our stationary and track-mounted plants, and provide versatility for ideal application flexibility.



Model	Dimension (H x W x L)		Total Weight		Max. Feed Size		Capacity	
	Feet	Meters	Pounds	Kilograms	Inches	Millimeters	TPH	MTPH
CS4233CC	13.42 x 12 x 63.67	4.09 x 3.65 x 19.4	110,000	49,895	21	533.4	275	249
CS4250	13.42 x 11.92 x 55.5	4.1 x 3.7 x 16.9	94,000	42,638	21	533.4	600	544
CS4250CC	15.5 x 14.5 x 69.33	4.7 x 4.4 x 21.1	107,880	48,934	21	533.4	600	544
SS4250	17.5 x 21.67 x 62.83	5.3 x 6.6 x 19.2	99,390	45,083	21	533.4	600	544
CS5260	14.5 x 11.92 x 51.08	4.4 x 3.7 x 15.6	125,300	56,835	21	533.4	800	726
SS5260	17.58 x 11.75 x 62.58	5.4 x 3.6 x 19.1	110,840	50,276	21	533.4	800	726
ProSizer® 3100	21.75 x 44 x 71.08	6.68 x 13.41 x 21.67	82,000	37,195	6	152.4	200	181
ProSizer® 3600	25 x 35 x 75	7.62 x 10.67 x 22.86	122,000	55,338	12	304.8	300	272
ProSizer® 4200	18.25 x 23.17 x 68	4.27 x 7.07 x 20.73	105,700	47,945	21	533.4	300	272

Available as



Track-Mounted



Portable



Stationary

5054 Hybrid HSI Plant

Improving upon the designs of the New Holland and Andreas HSI crushers, the 5054 Hybrid Impact Crusher features the most up-to-date technology in impact crushing, delivering the ability to process more material. The removable blow bars provide greater ease-of-use and less downtime, and the enhanced adjustable curtain delivers a more consistent product. With easy access to the crushing chamber, there are fewer maintenance issues, reducing downtime. The large expansion chamber allows more material to be processed, increasing productivity.

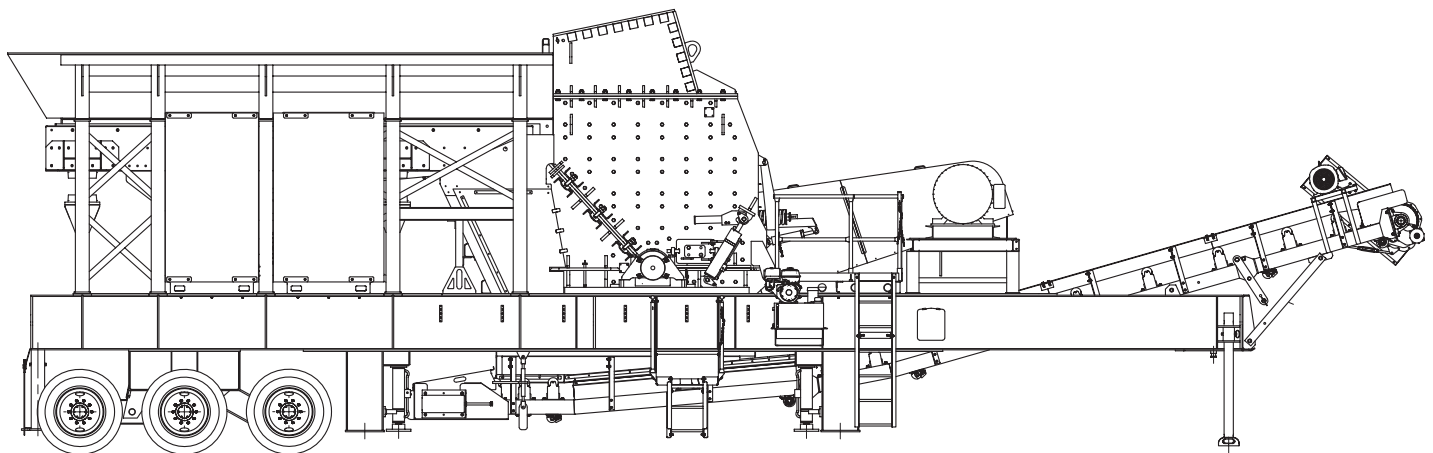

High Reduction Ratio

The 5054 Hybrid Impact Crusher provides a high reduction ratio and a large expansion chamber for increased production with less horsepower.

Crushing Chamber Opening

The upper section of crushing chamber opens for safe and easy maintenance access.

Removable Blow Bars

Removable blow bars provide greater ease-of-use, less downtime and multiple metallurgy for a variety of applications.

Plant Configuration

With a wide variety of options, including feeder sizes, belt width and axle configuration, our 5054 Hybrid HSI plant can be configured to suit a large variety of demanding applications.

Durable Construction

Equipped with an I-beam frame, heavy-duty axles and AR-lined chutes, our portable 5054 Hybrid HSI plant is engineered for maximum durability and high resale value.



Portability

Our portable plants offer the same efficient and reliable performance as our stationary and track-mounted plants, and provide versatility for ideal application flexibility.



Model	Diesel Power Required		Electric Power Required		Max. Feed Size		Capacity	
	HP	kW	HP	kW	Inches	Millimeters	TPH	MTPH
VS5054	440	336	300	224	40	1,016	500 - 900	454 - 816

Available as

Portable Stationary

VSI Plants

The efficient and versatile design of our portable Vertical Shaft Impactor (VSI) plants deliver highly-consistent end products for jobs that demand precision. These plants produce up to 500 tons per hour and have the option of running in standard, semi-autogenous and fully-autogenous configurations. Capable of meeting the most stringent material specs, our portable VSI crushing plants allow you to meet the challenges of any job you face.

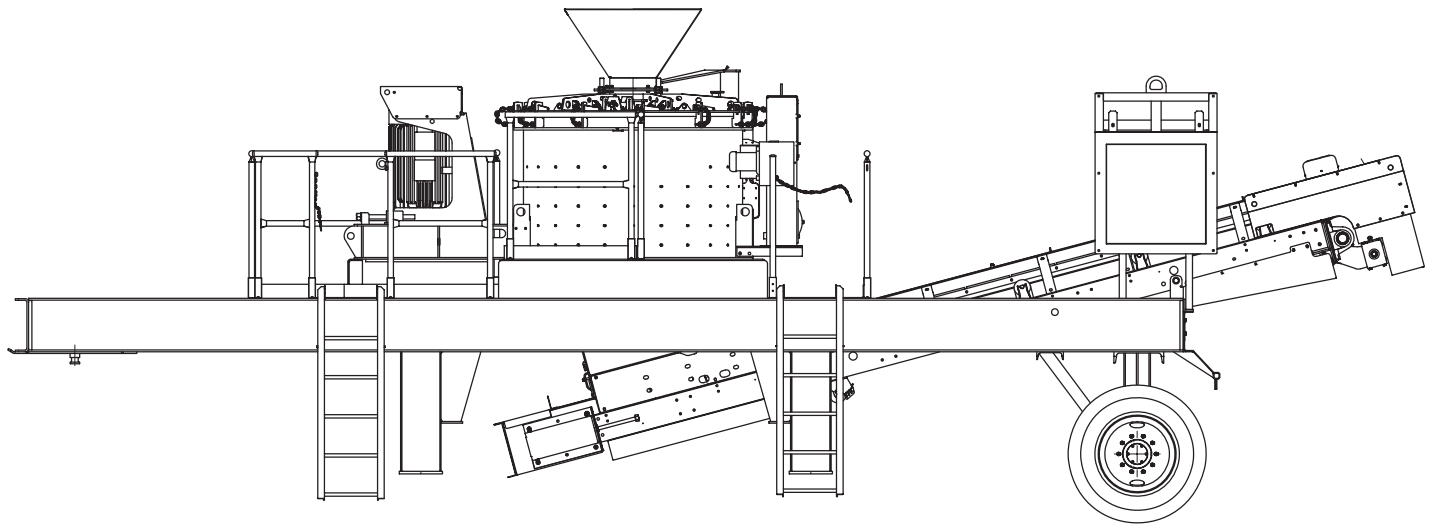

Rotor and Hybrid Rock Shelf Flexibility

Multiple configurations of rotor and hybrid rock shelf design deliver proper internal crusher geometry for maximum production at the lowest cost.

Optional Hydra-Arm

Optional hydra-arm assembly lifts the crusher lid for 360 degrees of internal crusher viewing and maintenance. Lid assembly is equipped with bolt-on liners and large inspection doors for internal component viewing and safe, easy access to wear liners.

Adjustable Anvil Ring

Adjustable anvil ring provides proper alignment for maximum efficiency and anvil utilization.

Externally-Adjustable Feed Tube

Heavy-duty construction and an externally-adjustable feed tube compensate for excessive wear normally experienced by other non-adjustable systems.

Portability

Our portable plants offer the same efficient and reliable performance as our stationary and track-mounted plants, and provide versatility for ideal application flexibility.



Model	Dimension (H x W x L)		Total Weight		Max. Feed Size		Capacity	
	Feet	Meters	Pounds	Kilograms	Inches	Millimeters	TPH	MTPH
1500EV(H)	12.92 x 10.83 x 35.5	3.9 x 3.3 x 10.8	30,460	13,816	2	50.80	75 - 150	67 - 135
2500EVT(H)	13.42 x 11.5 x 41.92	4.1 x 3.5 x 12.2	48,360	21,936	3	76.20	150 - 300	135 - 267
3500EVT(H)	15.25 x 11.08 x 38.08	4.6 x 3.4 x 11.6	57,000	25,855	3	76.20	300 - 350	267 - 317
4500EVT(H)	15.5 x 12.0 x 38.08	4.7 x 3.4 x 11.6	58,260	26,426	5	127.00	300 - 500	267 - 445

Available as



Track-Mounted



Portable



Stationary

Kodiak® Cone Crusher Plants

Our portable cone crushing plants feature our patented heavy-duty Kodiak® Plus roller bearing cone crusher. Ranging from 200-500 horsepower and engineered for versatility, these plants are ideal for secondary or tertiary crushing applications and offer open- and closed-circuit designs that allow producers to meet ever-changing needs.

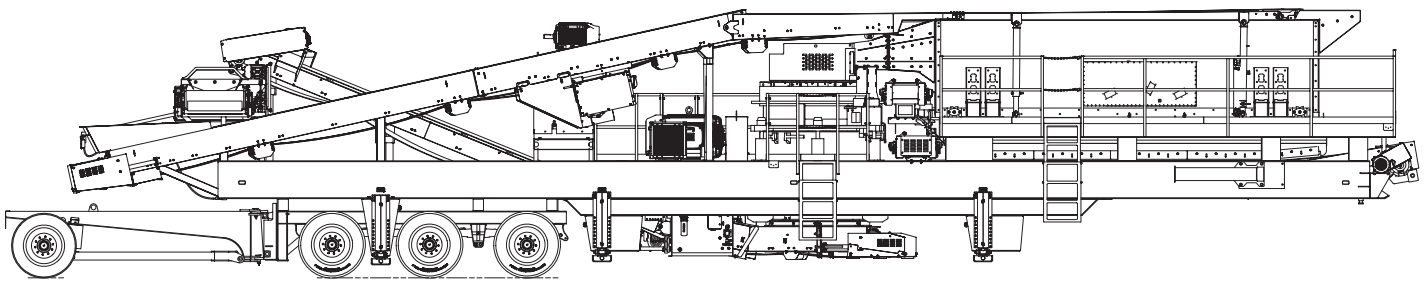

Standard Cone Plants

Our standard portable cone crushing plants feature a heavy-duty Kodiak® Plus roller bearing cone crusher with a 42-inch rear discharge conveyor or optional 42-inch front discharge conveyor and overflow feed chute.

In & Out Cone Plants

Our In & Out cone crushing plants feature a Kodiak® Plus Cone Crusher, a 42-inch rear feed conveyor, a 42-inch rear discharge conveyor and come standard with an overflow feed chute. These plants are designed specifically to operate in closed circuit with a plant-mounted feeder conveyor (PMFC) screening plant.

Portable Cone and Screen Plants

Our portable cone and screen plants feature a Kodiak® Plus Cone Crusher and a triple-shaft horizontal low-profile screen. These closed-circuit plants contain a reversing cross conveyor for open-circuit operation. Multiple axle configurations are available to meet producers' portability needs. Various product discharge chutes or cross conveyor options are available, as well as feed conveyor drive options.



Model	Cone	Screen	Maximum Capacity		Travel Dimensions (H x W x L)	
			TPH	MTPH	Feet	Meters
K200PM	K200+	-	385	350	12.92 x 10.42 x 48	3.94 x 3.17 x 14.63
K200/6203CC	K200+	6203-32LP	385	350	14 x 12 x 73.67	4.26 x 3.65 x 22.45
K300PM	K300+	-	460	417	13.17 x 11.25 x 48	4.01 x 3.43 x 14.63
K300PM In & Out	K300+	-	460	417	13.33 x 11.92 x 64.17	4.06 x 3.63 x 19.55
K300/6203CC	K300+	6203-32LP	460	417	14 x 12 x 73.67	4.26 x 3.65 x 22.45
K400PM	K400+	-	625	567	13.83 x 11.25 x 48	4.22 x 3.43 x 14.63
K400PM In & Out	K400+	-	625	567	13.5 x 11.92 x 64.17	4.11 x 3.63 x 19.55
K500PM	K500+	-	830	753	13.83 x 11.92 x 50.33	4.22 x 3.63 x 15.34

Available as



Track-Mounted



Portable



Stationary

Screening Plants

Our portable screening plants are engineered to provide higher production capacities and more efficient sizing compared to competitive screens. Engineered for a variety of applications, our screening plants enable producers to succeed in a variety of markets including recycle, aggregate, mining, biomass and industrial materials. We offer the industry's broadest product offering, including oval stroke horizontal, incline and high frequency screening plants.

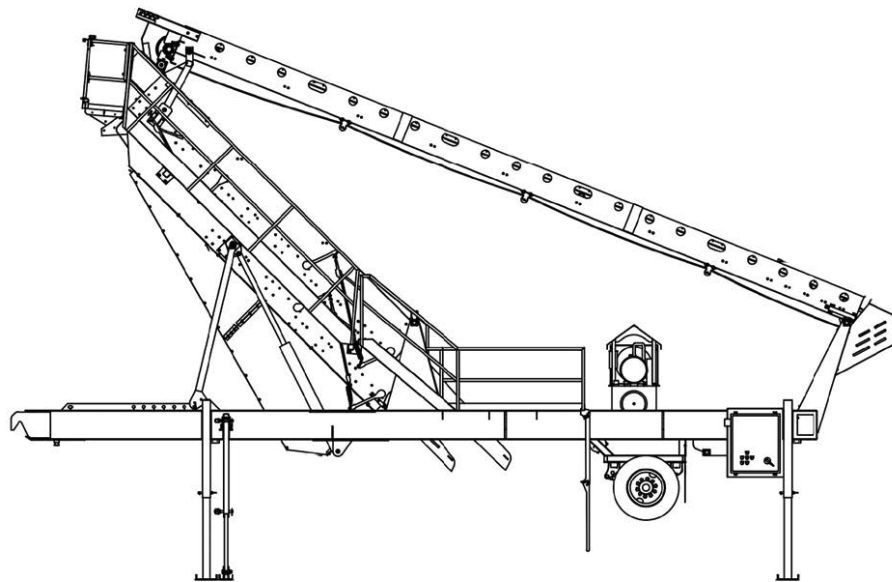

Application Flexibility

Screening plant designs allow for a variety of applications, ranging from scalping to finishing screens for recycle, aggregate, mining, biomass and industrial materials.

Product Diversity

Our portable screening plant line offers the industry's broadest product offering, including oval stroke horizontal, incline and high frequency screening plants.

Flexible Design

The flexible designs on our portable screening plants are custom-engineered to meet most height and weight restrictions.

Blending Capabilities

Industry-leading blending capabilities allow for the production of many different specifications, offering exceptional flexibility and performance.

Superior Support

Our portable screening plants are engineered to exact specifications and backed with 24/7 parts and service support.

Portability

Our portable plants offer the same efficient and reliable performance as our stationary and track-mounted plants, and provide versatility for ideal application flexibility.



Model	Speed	Max. Stroke		Max. Feed		Slope	Screen Size Range	
	RPM	In.	mm	In.	mm	Degrees	Feet	Meters
Incline Screens	1,200	0.38	9.5	6	152	18°-35°	4 x 8 <i>up to</i> 5 x 12	1.2 x 2.4 <i>up to</i> 1.5 x 3.7
Horizontal Screens	675 - 875	0.75	19	10	254	0°	6 x 20 <i>up to</i> 8 x 24	1.8 x 6.1 <i>up to</i> 2.4 x 7.3
Combo Screens	675 - 875	0.75	19	10	254	20°/10°/0°	6 x 20 <i>up to</i> 8 x 20	1.8 x 6.1 <i>up to</i> 2.4 x 6.1
High Frequency Screens	1,200 / 4,200	0.09	2.4	6	152	38° - 45°	6 x 12 <i>up to</i> 6 x 18	1.8 x 3.7 <i>up to</i> 1.8 x 5.5

Available as



Track-Mounted



Portable



Stationary

Material Handling Plants

Our portable material handling plants offer versatility for today's producers. With a wide range of innovative products to move, blend and stockpile any material, we have the right design, components, installation and support for every operation.

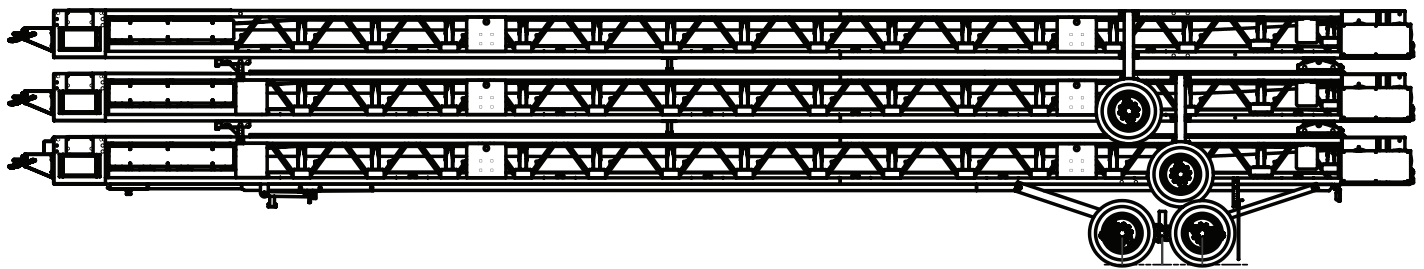

Portable Radial Stackers

Our radial stackers offer versatility for today's producers. Available in standard sizes up to 42" x 150', our conveyors partner seamlessly with our full line of portable and stationary crushing, screening and material handling equipment. Incredibly easy to set up, our radial stackers will have you moving material in no time.

Portable Roll-Pack Stackables

A set of three 70' transfer conveyors with 36" or 42" belt widths is available for producers on the move. Roll-Pack assemblies provide for quick and easy set-up; rolls apart in minutes for immediate use. Quick set-up and tear-down features minimize labor costs and move times.

Portable Pugmill Plants

The Model 52 pugmill is a portable mixing plant used to blend liquid and/or dry additives to one or two feed materials. The continuous-mix pugmill's PLC Automation controls blending and proportions for a quality mix. A unique spiral paddle design offers aggressive mixing for homogenous products. Portable plants provide flexibility to mix multiple products for many applications.

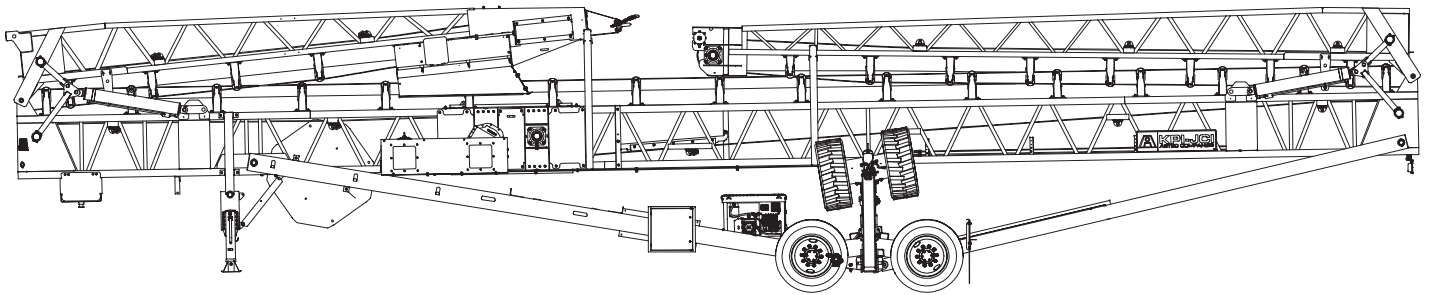

Available as



Portable



Stationary

Washing and Classifying Plants

Our industry-leading portable washing and classifying plants are engineered to maximize performance. We offer the widest selection of equipment in the industry, including log washers, coarse material washers, fine material washers, blademills, classifying tanks, washing and screening plants and dewatering screens. We also exclusively offer our Series 9000 family of products, which are custom-engineered and built for each application. Unlike some manufacturers, we build customized systems that deliver the highest return for the producer.

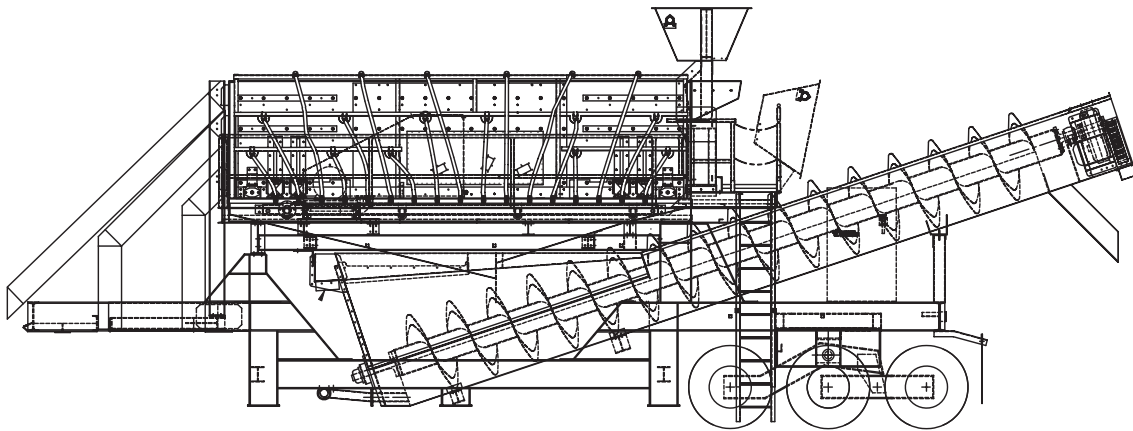

Series 1800

Our portable Series 1800 plants offer our fine material washer with an array of configurations — including blademills, inclined or horizontal wet single- or triple-shaft screens with two or three decks — all on a single chassis. Our patented PHB models are the largest portable plants offered by any American manufacturer, providing unsurpassed capacity and producing cleaner, higher-quality products.

Series 7000

Our portable classifying tanks are engineered to maximize profitability. The process begins with our Spec Select® Windows-based controllers and 24-volt DC bridge design, which allow simple control of the products, system monitoring and reporting features right from the controller. The patented design eliminates internal tank support members, creating less turbulence and more accurate settling of the feed material. Available in sizes from 8' x 20' up to 12' x 48', these systems are unmatched by anything the industry has to offer.

Series 9000

Our portable Series 9000 products are custom-engineered and built for each application, ensuring equipment performs as intended from initial commissioning through its production life. Products include classifying cyclones, dewatering screens, dewatering cyclones, pumps, attrition cells, density classifiers and sieve bend screens. Unlike some manufacturers, we focus on building customized systems that deliver the highest return for the producer.

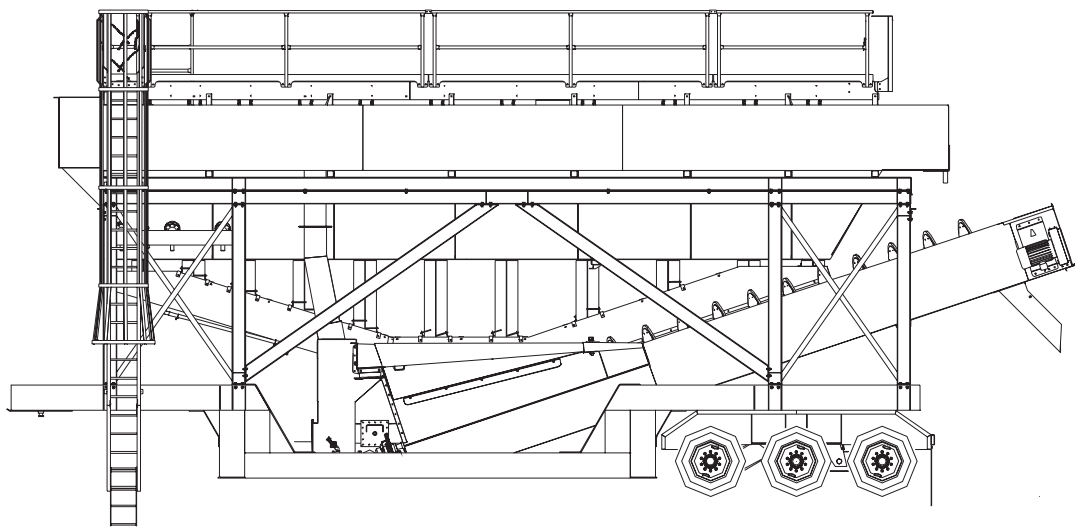

Available as



Portable



Stationary

Fast Pack[®] System

The Fast Pack[®] system is our innovative, patented combination of crushing, screening and stockpiling equipment. This system is proven to increase profitability by reducing operating personnel and energy cost per ton, reducing mobilization time, improving product quality and increasing production of spec material in varying conditions.

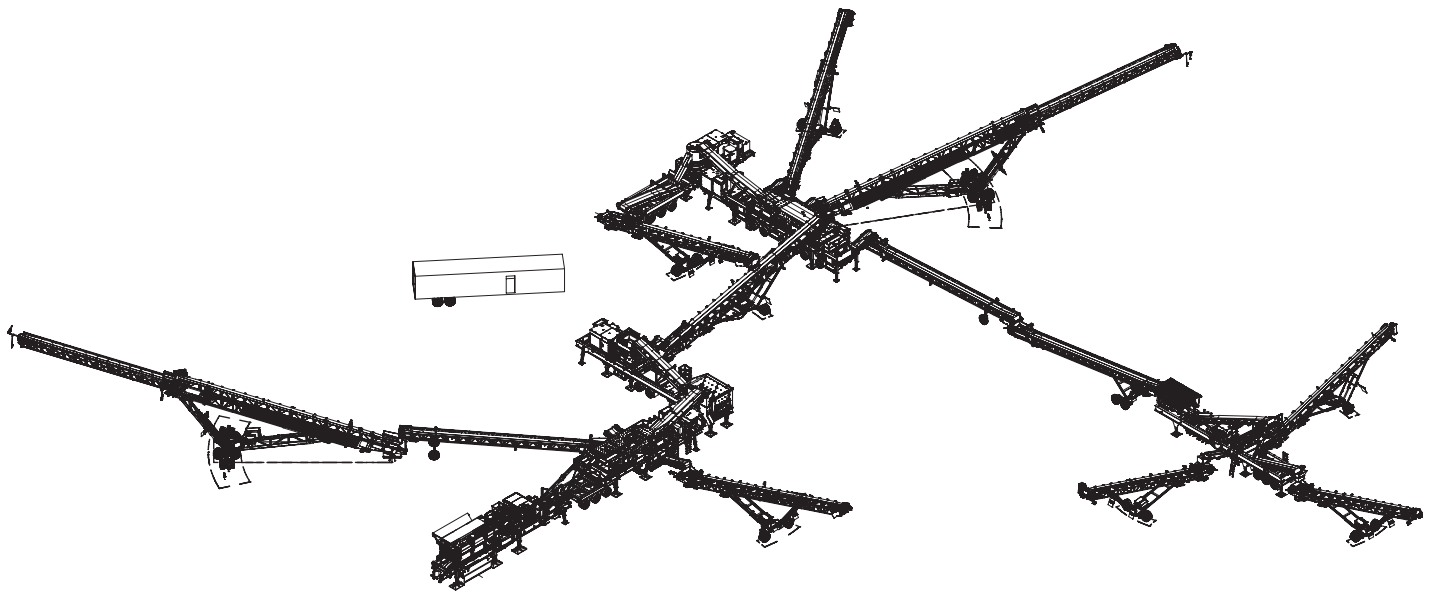

Portability

The Fast Pack[®] system reduces mobilization time and replaces moving days with production days. In-pit moves reduce haul costs and make small jobs economically feasible.

Increased Profitability

The Fast Pack[®] system increases profitability by increasing plant availability and decreasing operating personnel, while reducing energy cost-per-ton, mobilization expense and production and labor costs.

Improved Safety

Job site safety is enhanced by eliminating cribbing and heavy electrical cables, decreasing the number of conveyors, adding folding walkways, conveyors and bulkhead and reducing human interface.

Complete System

The system's flexible design allows it to operate as a whole or as individual, standalone components capable of stockpiling up to seven different products.

Product Quality

The Fast Pack[®] system ensures improved product quality through our industry-leading equipment, including the Pioneer[®] Series Jaw Crusher, Kodiak[®] Plus Cone Crusher, triple-shaft oval motion horizontal screen, Vari Vibe[®] high frequency screen and SuperStacker[®] telescoping stacker.

High Production

The Fast Pack[®] system allows producers to replace several existing underutilized facilities with one high-production system, thus reducing operating costs at low volume sites.



Model	Weight		Travel Length		Travel Width		Travel Height	
	Pounds	Kilograms	Feet	Centimeters	Feet	Centimeters	Feet	Centimeters
3144 Primary Jaw	153,400	69,581	63.42	1,933	11.5	351	14.75	450
3055 Primary Jaw	178,540	80,984	80.17	2,443	11.92	363	13.92	424
3352 Primary Jaw	197,220	89,458	75.5	2,301	11.75	358	15.5	472
6060 Primary Impactor	195,490	88,673	75.42	2,299	11.42	348	15.5	472
K400+ Secondary Cone	136,455	61,895	65.58	1,999	12	366	14	427
5260 Secondary HSI	134,040	60,800	65	1,981	12	366	14	427
K400+ Tertiary Cone	116,080	52,653	58.25	1,775	11.92	363	13.83	422
2500 Tertiary VSI	111,300	50,485	65	1,987	12	366	14.42	439
8203 Scalp Screen	97,090	44,039	64	1,951	12	366	14	427
8203 Finish Screen	111,880	50,748	69.17	2,108	12	366	14	427
PSP 2618VM High Frequency Screen	71,990	32,654	65	1,987	10.92	333	13.5	411
33-36136 SuperStacker	56,000	25,401	87.16	2,662	11.5	353	13.5	411
Control Trailer	55,260	25,066	63	1,920	10	305	13.75	419

*Note: Weights and dimensions are approximate and depend on specific configuration. Consult the factory for more information.



Kolberg-Pioneer, Inc.

700 West 21st Street
Yankton, SD 57078 USA
P: (800) 542-9311 | (605) 665-9311
F: (605) 665-8858

Johnson Crushers International, Inc.

86470 Franklin Boulevard
Eugene, OR 97405 USA
P: (800) 314-4656 | (541) 736-1400
F: (541) 736-1424

Astec Mobile Screens, Inc.

2704 West LeFevre Road
Sterling, IL 61081 USA
P: (800) 545-2125 | (815) 626-6374
F: (815) 626-6430

www.kpijci.com

Because Kolberg-Pioneer, Inc., Johnson Crushers International, Inc. and Astec Mobile Screens, Inc. may use in their catalog and literature, field photographs of their products which may have been modified by the owners, products furnished by Kolberg-Pioneer, Inc., Johnson Crushers International, Inc. and Astec Mobile Screens, Inc. may not necessarily be as illustrated therein. Also continuous design progress makes it necessary that specifications be subject to change without notice. All sales of the products of Kolberg-Pioneer, Inc., Johnson Crushers International, Inc. and Astec Mobile Screens, Inc. are subject to the provisions of their standard warranty. Kolberg-Pioneer, Inc., Johnson Crushers International, Inc. and Astec Mobile Screens, Inc. do not warrant or represent that their products meet any federal, state, or local statutes, codes, ordinances, rules, standards or other regulations, including OSHA and MSHA, covering safety, pollution, electrical wiring, etc. Compliance with these statutes and regulations is the responsibility of the user and will be dependent upon the area and the use to which the product is put by the user. In some photographs, guards may have been removed for illustrative purposes only. This equipment should not be operated without all guards attached in their normal position. Placement of guards and other safety equipment is often dependent upon the area and how the product is used. A safety study should be made by the user of the application, and, if required additional guards, warning signs and other safety devices should be installed by the user, wherever appropriate before operating the products.

NOTE: SPECIFICATIONS ARE SUBJECT TO CHANGE WITHOUT NOTICE

Rev. 11/18