

Material Handling

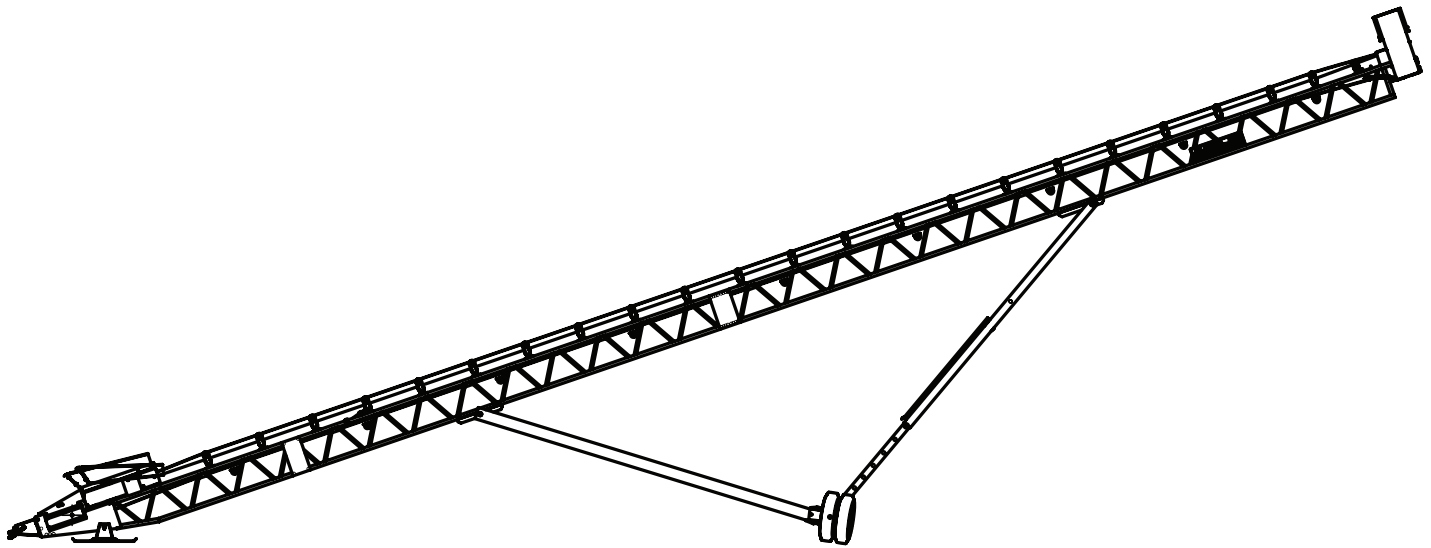

Radial Stackers

Kolberg-Pioneer radial stackers offer versatility for today's producers. Available in standard sizes up to 42" x 150', these conveyors partner seamlessly with our full line of portable and stationary crushing, screening and material handling equipment. Incredibly easy to set up, our radial stackers will have producers moving material in no time.



Top-Fold Frame

Optional manual or hydraulic top-folding frame is available on stackers 70' through 150'. Single- or double-fold options reduce load lengths for optimal portability.

Portability

Options such as power-fold head and tail sections, gullwing axles, air brakes and lighting packages offer quick set-up and superior road portability.

Optional Electrical Control

Electrical control panels with all necessary starters and wiring are installed by our UL-certified electrical department.

Compatibility

Hydraulic options allow our radial stackers to be powered by other Kolberg-Pioneer, Johnson Crushers International and Astec Mobile Screens equipment.

Quality Construction

All-jig-welded lattice frames with heavy-duty chord angles ensure a straight and reliable conveyor frame. Made in America by experienced personnel using proven manufacturing techniques to ensure unmatched quality.



Radial Stackers Stockpile Capacities*

Conveyor Length		Conical Pile		90-Degree Stockpile		180-Degree Stockpile		270-Degree Stockpile	
Feet	Meters	Ton	Metric Ton	Ton	Metric Ton	Ton	Metric Ton	Ton	Metric Ton
40	12.19	264	290	1,067	1,174	1,870	2,057	2,673	2,940
50	15.24	474	521	1,956	2,152	3,438	3,782	4,920	5,412
60	18.29	772	849	3,237	3,561	5,701	6,271	8,166	8,983
70	21.34	1,176	1,294	4,981	5,479	8,787	9,666	12,592	13,851
80	24.38	1,700	1,870	7,261	7,987	12,822	14,104	18,382	20,220
100	30.48	3,173	3,490	13,712	15,083	24,250	26,675	34,788	38,267
125	38.10	5,975	6,573	26,060	28,666	46,145	50,760	66,230	72,853
150	45.72	10,072	11,079	44,212	48,633	78,352	86,187	112,492	123,741

*Based on 100 pcf material and 37-degree angle of repose.

All Stackers available in 24", 30", 36" and 42" widths.

Different capacities and options are available. Contact the factory for details.

Available as



Track-Mounted



Portable



Stationary

SuperStacker® Telescoping Conveyor

Our SuperStacker® telescoping conveyor is essential to building a desegregated stockpile and ensuring product quality. Its innovative design allows producers to achieve up to 30% more stockpile capacity and its patented Wizard Touch® automation system automatically builds custom-desegregated stockpiles with increased capacity.

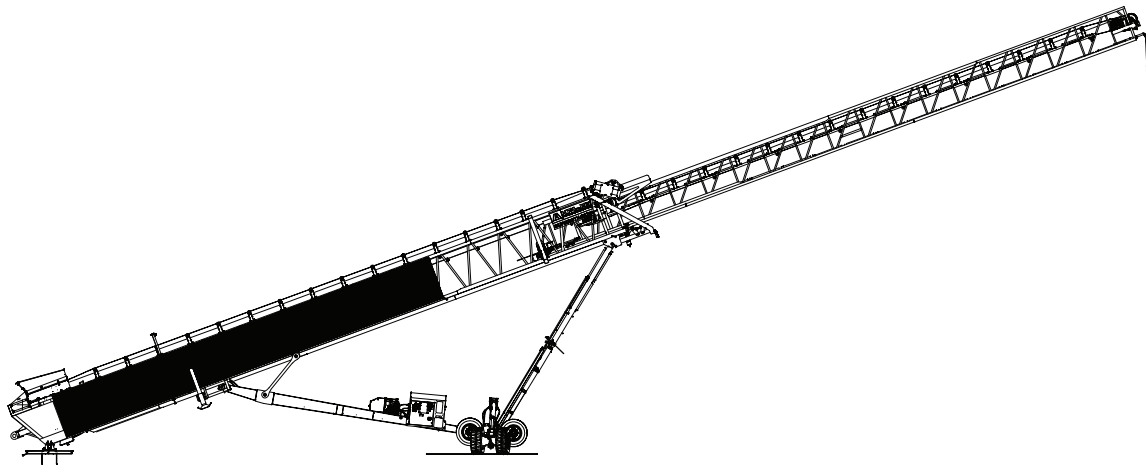

Wizard Touch® Automation

Our user-friendly Wizard Touch® program prevents material segregation and degradation by stockpiling windrows of material in incremental lifts. The automated processes include radial or inline desegregated, and full stockpile modes.

Cam-Arm Linkage

The cam-arm linkage connects the rear undercarriage to the conveyor frame with a floating connection. The cam-arm assembly maintains a constant radius from the pivot point to the axles, ensuring true radial movement and uninterrupted stockpiling. The cam-arm linkage creates a constant runway path, creating a wide footprint when raising and lowering the SuperStacker® conveyor and enhancing safety.

Built-In Counterweights

Our SuperStacker® conveyor features built-in counterweights to ensure safety and continued operations at all times.

Stockpile Capacity

The telescoping action creates stockpiles with 30% more capacity than a standard radial stacker of the same length.

Gullwing Axle

The gullwing axle on the SuperStacker® conveyor allows it to transform from highway portable to operational in minutes. Hydraulically-activated, fold-down arms eliminate the need for pins or chain removal for set-up.

Festoon System

Our festoon system enables the telescoping stinger conveyor to telescope in and out and offers a smoother, more reliable method of extending and retracting the stinger conveyor.

Application Flexibility

Our SuperStacker® conveyor excels in challenging job sites with limited footprints, and can load or unload by truck, rail or barge.



Model	Width		Length		Maximum Capacity		270-Degree Stockpile	
	Inches	Millimeters	Feet	Centimeters	TPH	MTPH	Tons	Metric Tons
33-30130	30	762	130	3,962	500	454	95,900	87,000
33-30150	30	762	150	4,572	500	454	151,900	137,800
33-36130	36	914	130	3,962	1,000	771	95,900	87,000
33-36136LP	36	914	136	4,145	1,000	771	91,700	83,200
33-36150	36	914	150	4,572	1,000	771	151,900	137,800
33-36170	36	914	170	5,181	1,000	771	201,900	183,100
33-36190	36	914	190	5,790	1,000	771	302,000	274,000
33-42150	42	1,067	150	4,572	1,500	1,364	151,900	137,800
33-42170	42	1,067	170	5,182	1,200	1,089	200,000	181,400

Available as



Portable

SuperStacker® Stockpiles

Our industry-leading SuperStacker® conveyor is designed to help customers meet increasingly demanding material specifications. Available in various sizes, the SuperStacker® conveyor gives producers the ability to stockpile in-spec aggregate in larger piles with smaller footprints using fully-automated PLC technology.

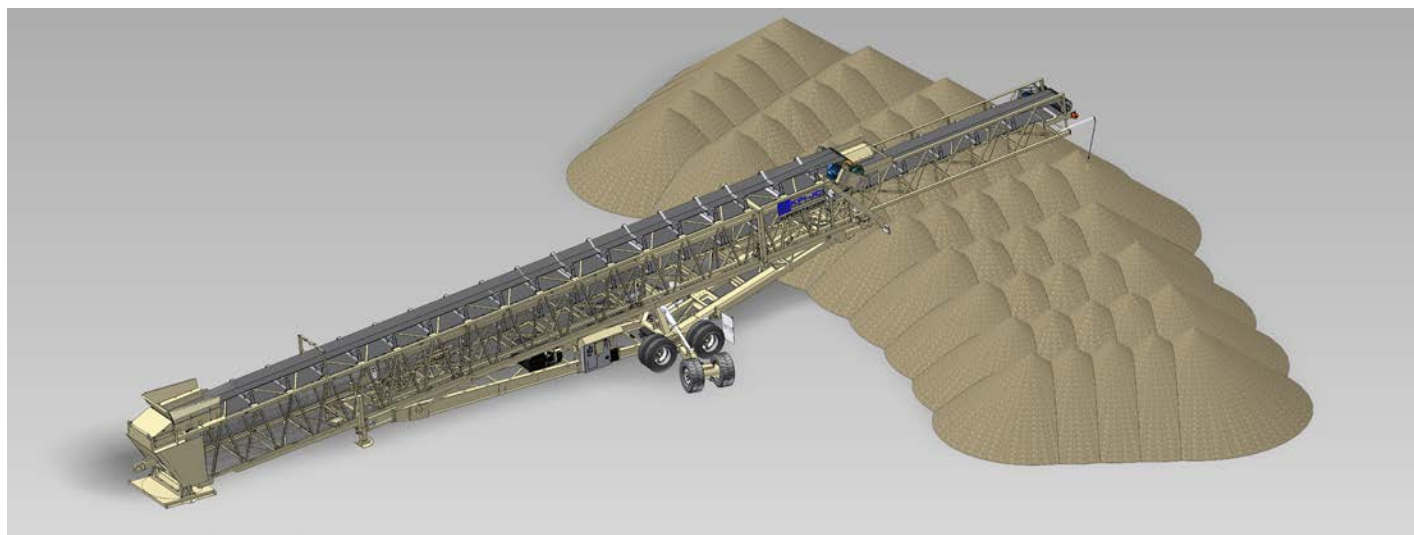

Radial Conical Pile



Wizard Touch®

Our new Wizard Touch® automation software program delivers the most revolutionary stockpile automation technology in the industry and is the key to an efficient operation and a high-quality product. The program prevents material segregation and degradation by stockpiling windrows of material in incremental lifts using a user-friendly, fully-programmable PLC controller. The Wizard Touch® automation creates a more consistent product, allowing producers to capture and maintain the investment made in aggregate products.

New Advancements

The latest advancements to the Wizard Touch® program expand the selection of stockpile options and the ability to input multiple stockpile recipes for a more diverse operation. A larger, 12-inch color touchscreen and user-friendly diagnostics make the program easy to use by anyone on the jobsite. Automated processes include radial or inline, conical or windrow stockpile modes.

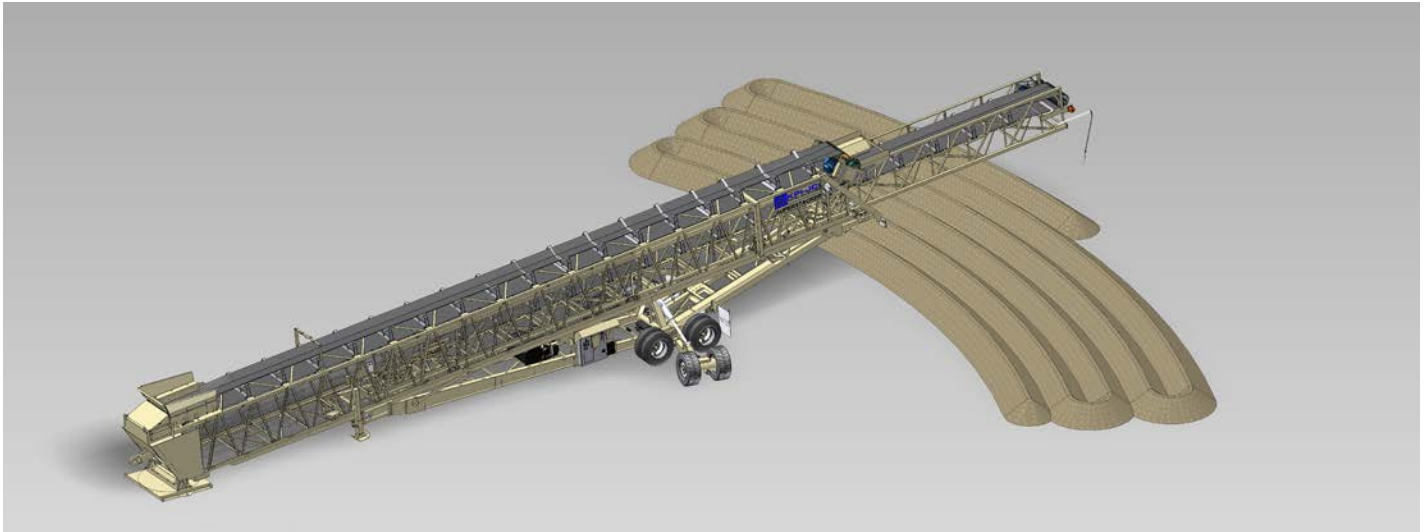

Radial Continuous Pile



Inline Continuous Pile

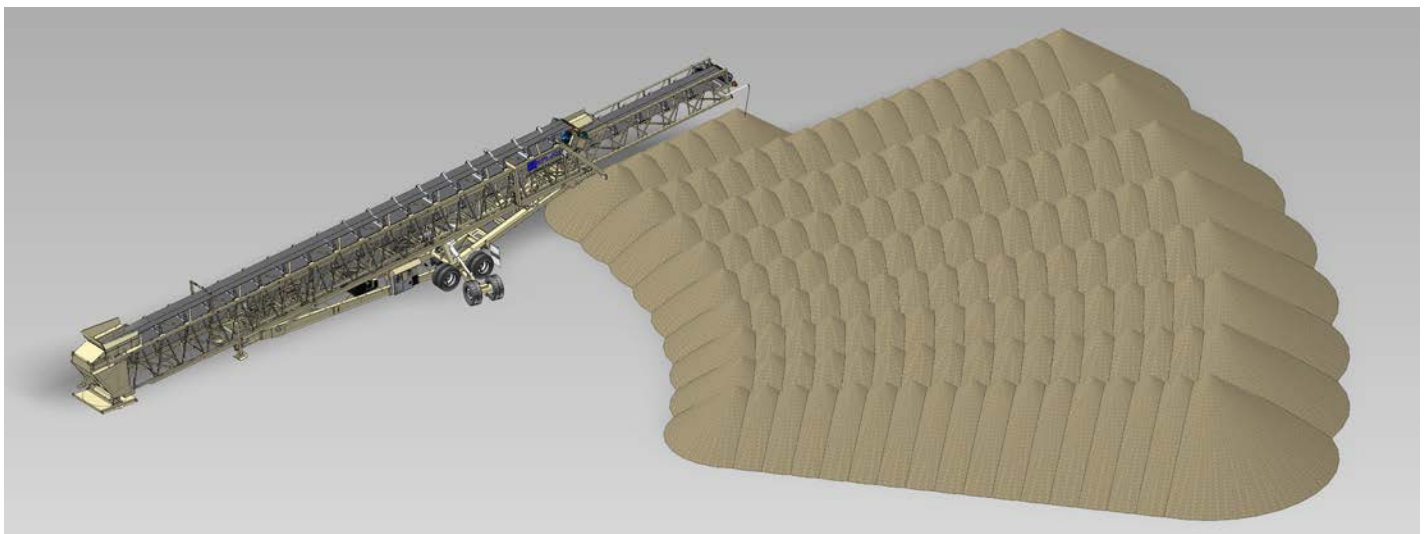

Inline Conical Pile

Transfer Conveyors

Kolberg-Pioneer has engineered transfer conveyors for all types of operations. For road portability or in-pit portability, our Trans Flite® transfer conveyors are the ideal solutions and available in skid-mount or dolly-axle configurations. Channel or lattice frame overland conveyors are available to cover longer distances, eliminating the need for haul trucks.

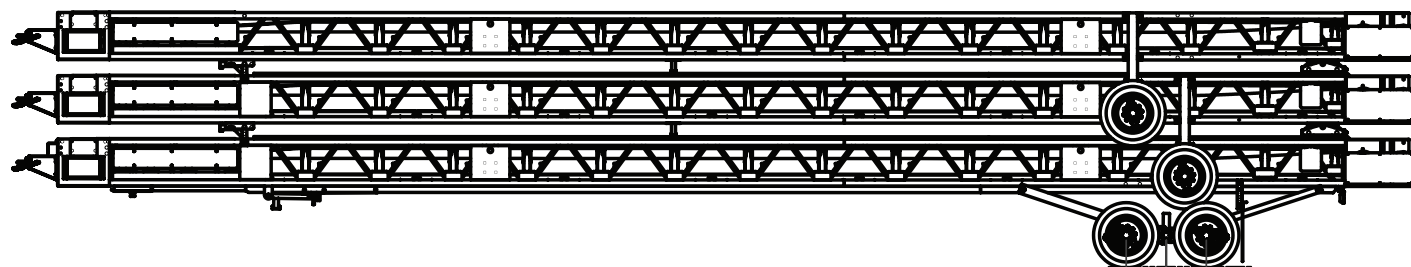

Stackable Conveyors

Our stackable conveyors pack up to 480 feet of conveying power in a single truckload, perfect for highly-portable operations. Up to eight, 60' conveyors fit per load. Available with numerous options to meet operational needs.

Roll-Pack Stackables

A set of three 70' transfer conveyors with 36" or 42" belt widths is available for producers on the move. Roll-Pack assemblies provide for quick and easy set-up; rolls apart in minutes for immediate use. Quick set-up and tear-down features minimize labor costs and move times.

Trans Flite®

Our easily re-locatable Trans Flite® transfer conveyors are available with a dolly axle or skid support. The conveyor's heavy-duty truss allows for effortless movement on site.

Overland Systems

Our overland systems eliminate the need and cost of haul trucks, while at the same time providing an environmentally-friendly means of moving product from one point to another. Available in channel or lattice frame construction in any length or belt width. Custom designed to fit any plant seamlessly.



Available Lengths												
Model	Feet	Meters	Feet	Meters	Feet	Meters	Feet	Meters	Feet	Meters	Feet	Meters
	40	12.19	50	15.24	60	18.29	70	21.34	80	24.38	100	30.48
Trans Flite®					X				X		X	
Stackables	X		X		X		X		X		X	
Roll-Pack							X					

Available as



Portable



Stationary

Feed Systems

The seamless compatibility of our entire line of material feed products allows producers to run at peak performance and maximize the effectiveness of their operations by improving material feed points. Our feeding equipment excels at efficiently feeding portable or stationary systems, and easily fits into new or existing operations.

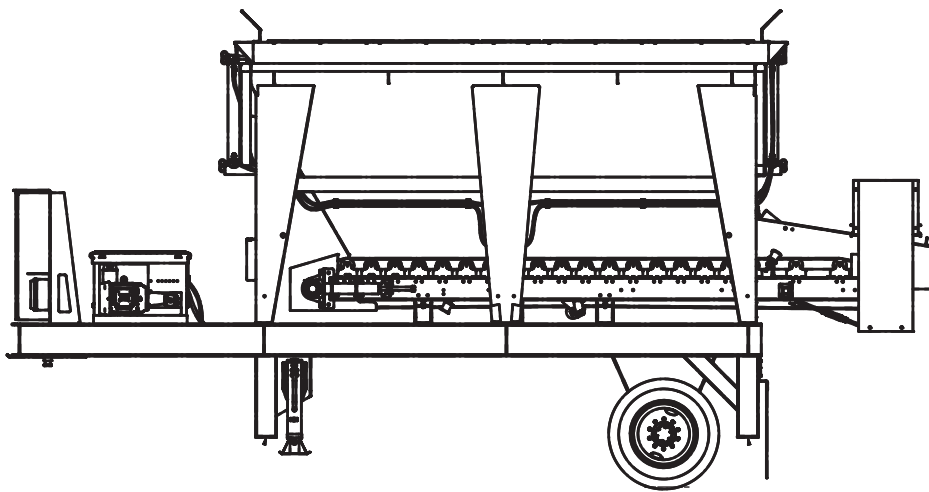

Portable Feed Systems

Feed systems are road-portable and offer quick set-up for producers. Numerous sizes and options available.

Hopper Feeders

Hopper feeders are loaded with material then fed material at a metered rate. Optional scalping grizzly available.

Tunnel Feed Systems

Pre-fabricated tunnel provides quick installation. Heavy-duty construction ensures system will not settle or deform. Numerous feeding options available.



Model	Hopper Capacity		Belt Feeder		Belt Conveyor		Capacity	
	Cubic Yards	Cubic Meters	Inches x Feet	mm x M	Inches x Feet	mm x M	TPH	MTPH
930-14-12	12	9.2	30 x 14	762 x 4.3	-	-	450	409
936-14-12	12	9.2	36 x 14	914 x 4.3	-	-	600	545
930-18-20	20	15.3	30 x 18	762 x 5.5	-	-	600	545
936-18-20	20	15.3	36 x 18	914 x 5.5	-	-	750	682
942-18-20	20	15.3	42 x 18	1,067 x 5.5	-	-	900	818
12-3060	10	7.6	30 x 8	762 x 2.4	30 x 60	762 x 18.3	450	409
12-3070	10	7.6	30 x 8	762 x 2.4	30 x 70	762 x 21.3	450	409
12-3660	10	7.6	36 x 8	914 x 2.4	36 x 60	914 x 18.3	600	545
12-3670	10	7.6	36 x 8	914 x 2.4	36 x 70	914 x 21.3	600	545
1430-60-20	20	15.3	36 x 16	914 x 4.9	30 x 60	762 x 18.3	500	455
1430-70-20	20	15.3	36 x 16	914 x 4.9	30 x 70	762 x 21.3	500	455
1430-80-20	20	15.3	36 x 16	914 x 4.9	30 x 80	762 x 24.4	500	455
1436-60-20	20	15.3	42 x 16	1,067 x 4.9	36 x 60	914 x 18.3	750	682
1436-70-20	20	15.3	42 x 16	1,067 x 4.9	36 x 70	914 x 21.3	750	682
1436-80-20	20	15.3	42 x 16	1,067 x 4.9	36 x 80	914 x 24.4	750	682

LowPro Drive-Over Truck Unloaders

The low, 3' profile of the 48" LowPro delivers the convenience, efficiency, ease-of-use and environmentally-friendly characteristics every operation demands. The drive-over truck unloader provides an efficient solution for unloading material wherever it is needed. The low profile allows producers to build smaller earthen ramps, cutting labor needs, fuel costs and set-up time.

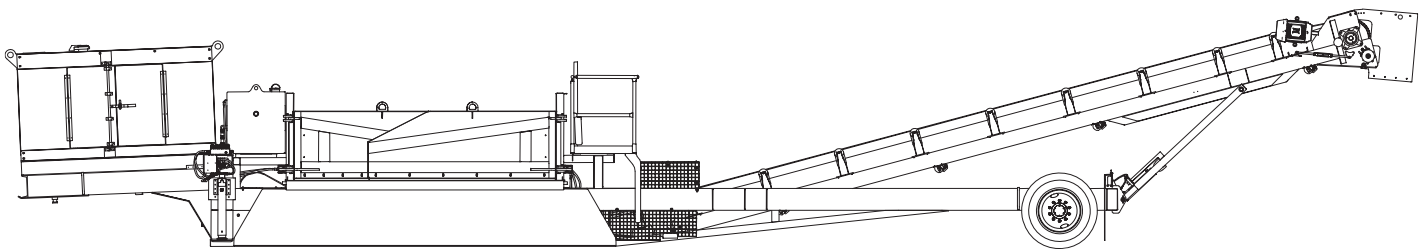

Low Profile

The 3' low profile allows producers to build smaller earthen ramps, cutting labor needs, fuel costs and set-up time.

Compact Design

The compact design makes it easy to move to multiple locations on site and eliminates time spent unloading, maximizing productivity.

Compatibility

The LowPro Drive-Over Truck Unloader pairs ideally with the SuperStacker® Telescoping Radial Stacker to maximize loads, minimize fuel costs and increase profitability. Optional on-plant diesel/gen-set available to power SuperStacker® conveyor.

Simple Setup

Quick and easy set-up reduces labor and fuel costs.



Model	Belt Conveyor		Adjustable Discharge Height		Ramp Height		Capacity	
	Inches x Feet	Millimeters	Feet	Centimeters	Feet	Millimeters	TPH	MTPH
2148-50LP	48 x 50	1,219 x 15,240	7.83 x 10.75	238 x 328	3	914	1,000	907

Available as



Portable

Pugmills

The Model 52 Pugmill is a portable mixing plant used to blend liquid and/or dry additives to one or two feed materials. The continuous-mix pugmill's PLC Automation controls blending and proportions for a quality mix. A unique spiral paddle design offers aggressive mixing for homogenous products. Portable plants provide flexibility to mix multiple products for many applications.

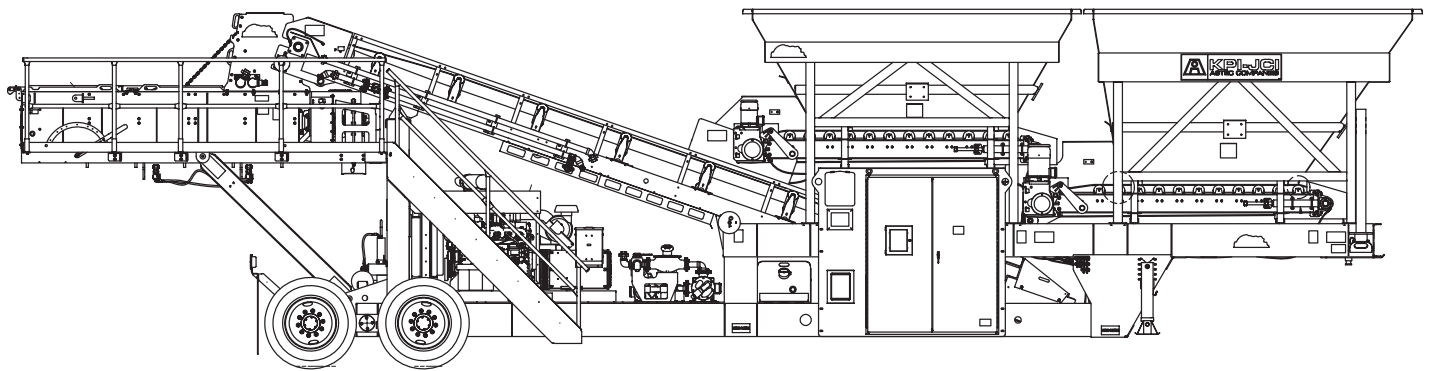

Adjustable Dam Gate

A dam gate is provided at the discharge end of the pugmill to ensure enough material is in the mixing zone.

Timed Gears/Spiral Paddle Arrangement

Using timed gears with one motor to drive both shafts allows for a unique interlocking spiral paddle arrangement. This creates a much more aggressive mixing action than competitive models, which use two motors.

Drop-Out Bottom

A drop-out bottom opens the entire unit for simplified clean-out and service access.

Applications

Applications include cement-treated base (CTB), roller-compacted concrete (RCC), cold-mix asphalt and stabilization.

Blending Automation

Once a mix recipe is selected, the PLC Automation system will maintain the correct proportion of ingredients as the operator increases or decreases the overall blending rate.

Accessible and Easy-to-Use Touch Screen Controls

Real-time monitors track on-plant motor loads, blending rate and feed rate of each material. Up to five different project-specific mix recipes can be stored at once.

Paddle Tips

The paddle tips are adjustable to accommodate varying sizes of feed material with a maximum particle size of two inches. Paddle tips can be rotated 90 degrees to increase retention time in the mixing chamber. Cast ni-hard paddle tips are reversible, resulting in lower wear costs.



Model	Pugmill Size		Motor	Primary Hopper Capacity		Secondary Hopper Capacity		Capacity	
	Inches x Feet	Centimeters	HP	Cubic Yards	Cubic Meters	Cubic Yards	Cubic Meters	TPH	MTPH
52 (Plant)	48 x 6	122 x 183	60	9	6.9	6.5	5	300	272
52S (Plant)	48 x 8	122 x 244	100	15	11.5	8	6.1	500	454
50-486	48 x 6	122 x 183	60	-	-	-	-	-	-
50-488	48 x 8	122 x 244	75	-	-	-	-	-	-
50-4810	48 x 10	122 x 305	100	-	-	-	-	-	-

Available as



Portable



Stationary

Stationary Conveyors/Systems

We offer a streamlined design of highly-productive material handling systems. From tripper systems to loading and unloading railcars, trucks or ships, we have the right design, components, installation and support for every application.

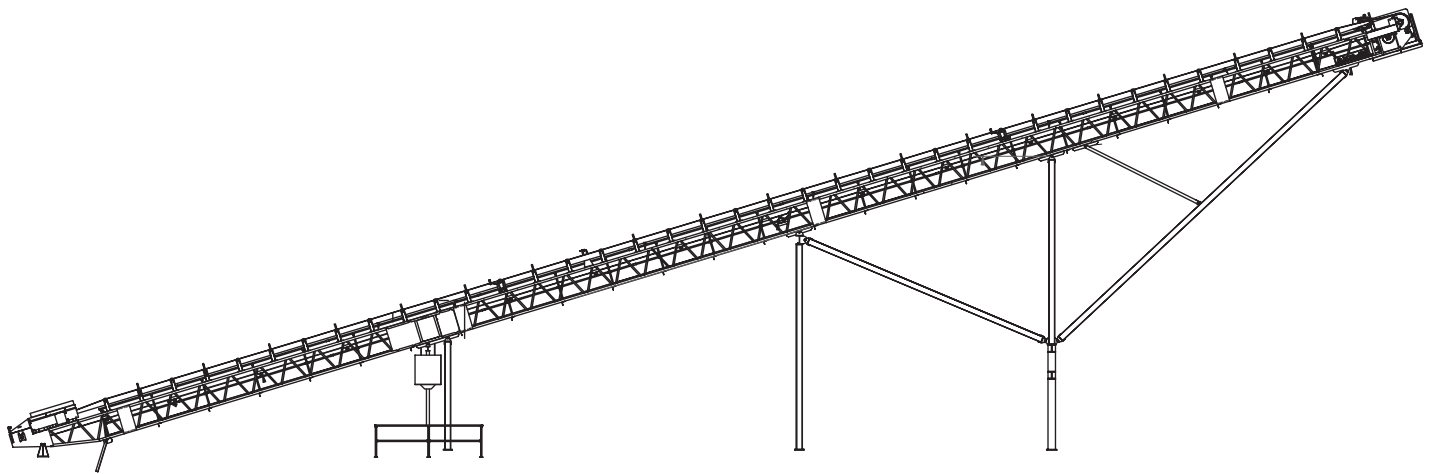

Loading/Unloading Systems

Our loading and unloading systems give producers options to load and unload material by truck, rail or barge. These systems include large unloading hoppers for unloading railcars, stationary or portable truck unloaders, and various conveyors for stockpiling.

Tripper Conveyors

Elevated tripper conveyors maximize storage capacity on limited real estate. Our tripper systems use a tripper cart to move along the length of the conveyor, stopping at various points along the way for stockpiling different products into bunkers.

Overland Conveyors

Overland conveyors eliminate the need and cost of haul trucks, while at the same time providing an environmentally-friendly means of moving product from one point to another.

System Conveyors

Our heavy-duty system conveyors tie everything together for a highly-efficient operation. These conveyors are engineered to fit seamlessly with our full line of crushing, screen and washing and classifying equipment.

Tunnel Reclaim

Our tunnel reclaim system maintains a continuous feed of material to the processing plant. These systems are designed to provide a surge pile of material to use in the processing side of the plants. This allows one part of the plant to operate while the other is shut down. Our pre-fabricated surge tunnels offer all-welded construction of heavy-duty steel. The vibrating feeders and tunnel conveyor are mounted in the tunnel at the manufacturing facility, making set-up quick and easy.



CONVEYOR ELEVATION CHART

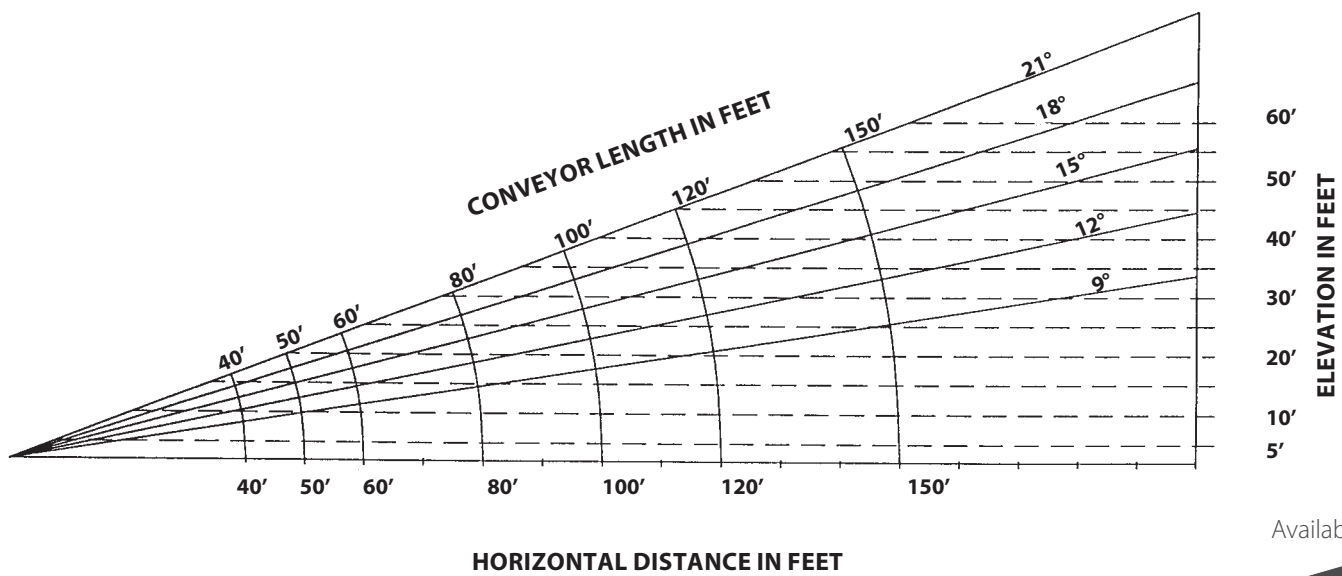

Available as



Stationary

Our Tradition

Legacies aren't built by the weak. Since his introduction in 1928, Rocky has become an icon for Kolberg-Pioneer, Johnson Crushers International and Astec Mobile Screens. Rocky serves as a powerful symbol of our longevity, our strength in the industry, and our commitment to our customers. When producers see Rocky, they see security.





Kolberg-Pioneer, Inc.

700 West 21st Street
Yankton, SD 57078 USA
P: (800) 542-9311 | (605) 665-9311
F: (605) 665-8858

Johnson Crushers International, Inc.

86470 Franklin Boulevard
Eugene, OR 97405 USA
P: (800) 314-4656 | (541) 736-1400
F: (541) 736-1424

Astec Mobile Screens, Inc.

2704 West LeFevre Road
Sterling, IL 61081 USA
P: (800) 545-2125 | (815) 626-6374
F: (815) 626-6430

www.kpijci.com

Because Kolberg-Pioneer, Inc., Johnson Crushers International, Inc. and Astec Mobile Screens, Inc. may use in their catalog and literature, field photographs of their products which may have been modified by the owners, products furnished by Kolberg-Pioneer, Inc., Johnson Crushers International, Inc. and Astec Mobile Screens, Inc. may not necessarily be as illustrated therein. Also continuous design progress makes it necessary that specifications be subject to change without notice. All sales of the products of Kolberg-Pioneer, Inc., Johnson Crushers International, Inc. and Astec Mobile Screens, Inc. are subject to the provisions of their standard warranty. Kolberg-Pioneer, Inc., Johnson Crushers International, Inc. and Astec Mobile Screens, Inc. do not warrant or represent that their products meet any federal, state, or local statutes, codes, ordinances, rules, standards or other regulations, including OSHA and MSHA, covering safety, pollution, electrical wiring, etc. Compliance with these statutes and regulations is the responsibility of the user and will be dependent upon the area and the use to which the product is put by the user. In some photographs, guards may have been removed for illustrative purposes only. This equipment should not be operated without all guards attached in their normal position. Placement of guards and other safety equipment is often dependent upon the area and how the product is used. A safety study should be made by the user of the application, and, if required additional guards, warning signs and other safety devices should be installed by the user, wherever appropriate before operating the products.

NOTE: SPECIFICATIONS ARE SUBJECT TO CHANGE WITHOUT NOTICE

Rev. 1/19